

Electrical connections

This worksheet and all related files are licensed under the Creative Commons Attribution License, version 1.0. To view a copy of this license, visit <http://creativecommons.org/licenses/by/1.0/>, or send a letter to Creative Commons, 559 Nathan Abbott Way, Stanford, California 94305, USA. The terms and conditions of this license allow for free copying, distribution, and/or modification of all licensed works by the general public.

Resources and methods for learning about these subjects (list a few here, in preparation for your research):

Questions

Question 1

What, exactly, is necessary to establish electrical *continuity* between two wires? If I want to have an electric current flow out of one wire and into another, what must be done with those two wires to make that flow path complete?

Conversely, what things might prevent continuity from being established between two wires when they are supposed to electrically connect with one another?

[file 00231](#)

Question 2

What is the difference between a *plug* and a *jack*? What are these two devices used for? Draw the schematic diagram symbols for single-conductor plugs and jacks.

[file 00232](#)

Question 3

What is a *terminal block*, or *terminal strip*? How are these devices used to make electrical connections between different conductors?

[file 00234](#)

Question 4

What is generally considered to be the maximum number of individual wires that may be attached to a single terminal on a terminal block?

[file 00238](#)

Question 5

Wire nuts are special electrical connection devices commonly used in residential power wiring. Describe what a "wire nut" is and how they are used to make connections between wires.

[file 00239](#)

Question 6

What is *soldering*? What is *solder*?

[file 00233](#)

Question 7

How are connections made between the various wire ends of components inserted into *printed circuit boards* ("PCBs")?

[file 00235](#)

Question 8

An alternative to *soldering* components into printed circuit boards is to use a technique called *wire wrap*. Describe what "wire wrap" is and what applications it might be suitable for.

[file 00236](#)

Question 9

What type of electrical test would be the most direct means of checking the integrity of an electrical connection between two conductors? Explain your answer.

[file 00237](#)

Question 10

Suppose this circuit has a problem: the light bulb does not light up when the switch is turned "ON". You suspect that a "bad" connection may exist in the circuit which is preventing current. How would you test the integrity of each connection using a voltmeter only?

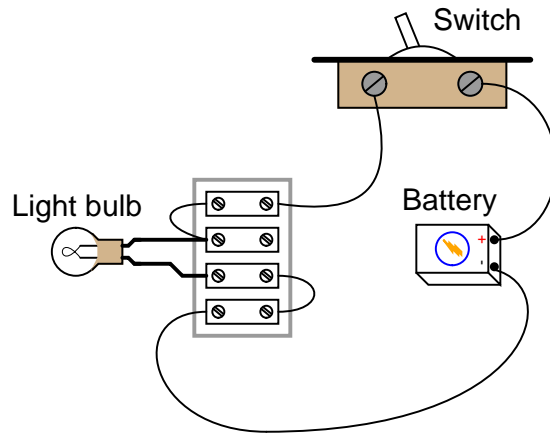

file 00240

Question 11

Map the interconnections between holes in a typical *solderless breadboard*, also commonly known as a *proto-board*:

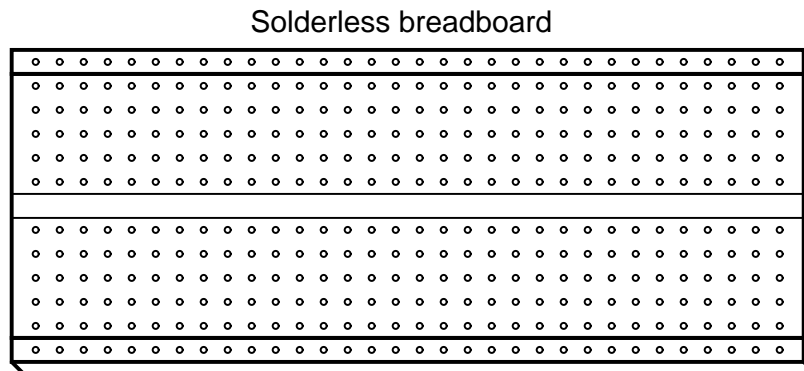

file 01762

Question 12

Show how to build a simple circuit consisting of a battery, a lamp, and a switch, mounting the lamp and switch on a *solderless breadboard* (also known as a *proto-board*):

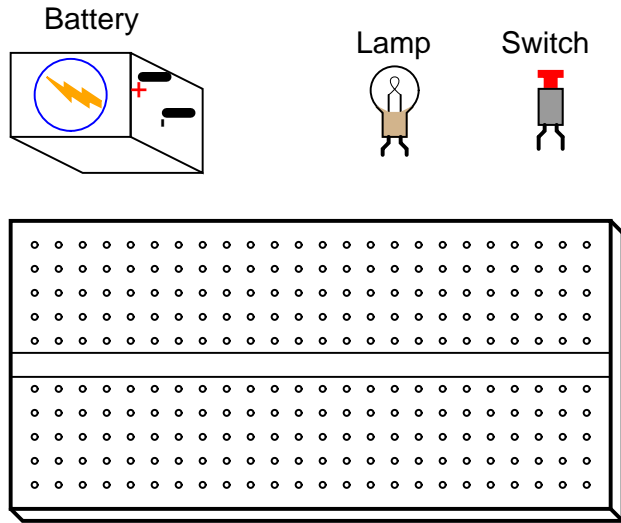

file 01763

Question 13

Solderless breadboards provide convenient means for electronics hobbyists, students, technicians, and engineers to build circuits in a non-permanent form. The following illustration shows a three-resistor series circuit built on a breadboard:

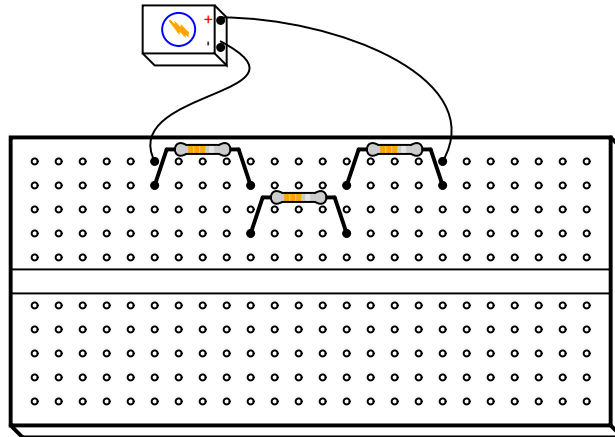

The interconnections between the metal spring clips within the holes of the breadboard allow continuity between adjacent leads of the resistors, without the resistor leads having to be jammed into the same hole.

However, new students often get themselves into trouble when first learning how to use solderless breadboards. One common mistake is shown here, where a student has attempted to create a simple single-resistor circuit:

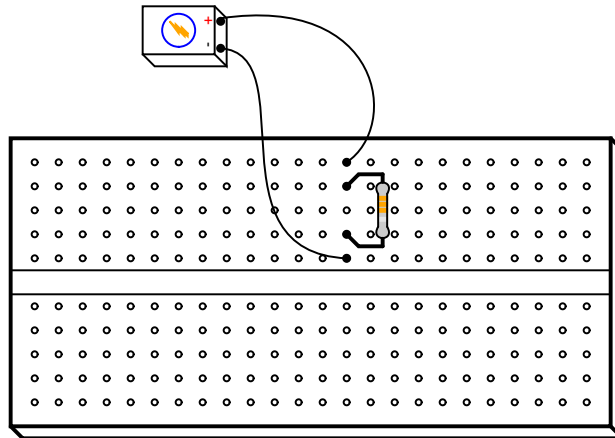

What the student has actually created here is a *short circuit*. Re-draw this circuit in schematic form, and explain why this circuit is faulty.

[file 01761](#)

Answers

Answer 1

There must be metal-to-metal contact between the two wires in order to establish electrical continuity between the two. Anything preventing this clean contact between metal surfaces will inhibit continuity. This includes dirt, dust, oil, corrosion, misplaced insulation, and the like.

Answer 2

A "plug" is the male half of a temporary electrical connector, while the "jack" is the female half. Electrical connectors are used to make convenient connections between individual wires or sets of wires.

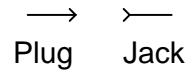

Answer 3

Terminal "blocks" or "strips" are rows of short, metal blocks with screws or other fastener devices used to make firm mechanical bonds to conductors:

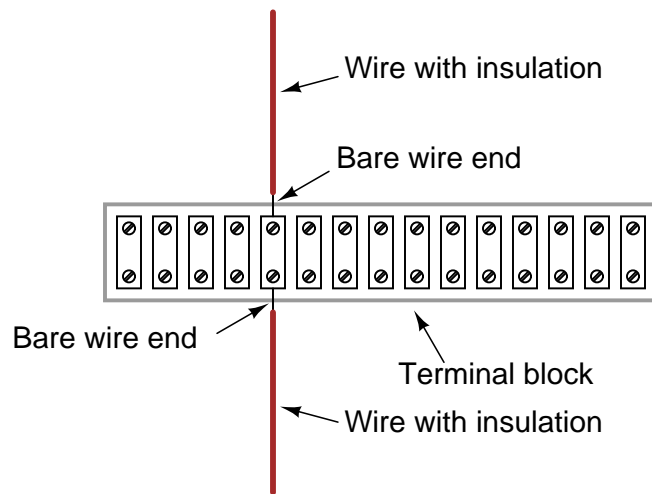

Sometimes, terminal blocks also go by the name of "barrier strips."

Answer 4

Two wires per fastener, maximum:

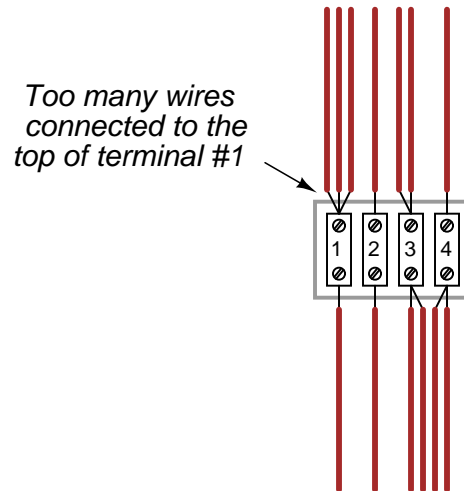

Answer 5

"Wire nuts" are electrical fasteners which use a coiled spring to clasp bare metal wire ends together. The "nut" is screwed on to the ends of two or more wires to be joined, as though it were a nut being threaded onto a bolt. The coils of the spring inside the nut function as threads, which grip the wire ends tighter as the nut is turned clockwise over them.

Answer 6

"Soldering" is a low-temperature form of welding commonly used to join electrical conductors together for permanent connections.

"Solder" is a special alloy of metals designed to melt at a low temperature, to make permanent electrical connections.

Answer 7

Component wire ends are typically soldered onto strips of copper metal (called "traces") affixed on the surface of the printed circuit board material, which itself is electrically insulating.

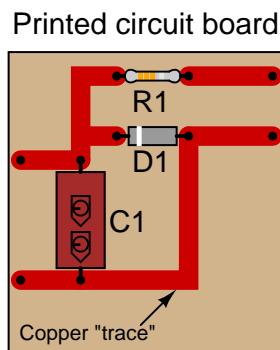

Answer 8

"Wire wrap" is a connection technique for joining components together on a circuit board without need for pre-printed copper "traces" on the board. Instead, small-gauge wire is tightly wrapped around the pins of each component, with the wire making point-to-point connections between components.

Answer 9

An electrical *resistance* test.

Answer 10

If voltage is measured across any connection of two wires, that connection is definitely faulty.

Answer 11

Lines indicate continuity (electrically common holes)

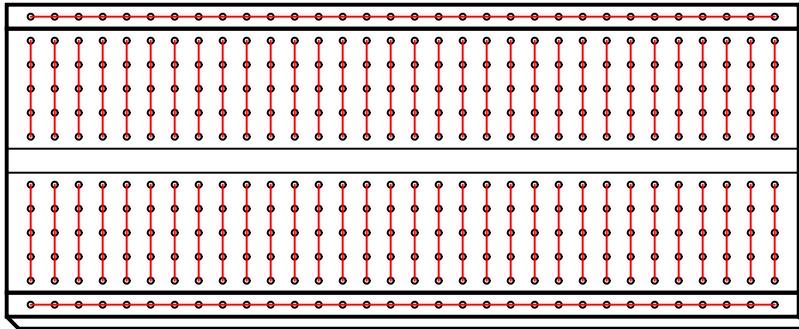

Answer 12

This is just one possibility – there are many others!

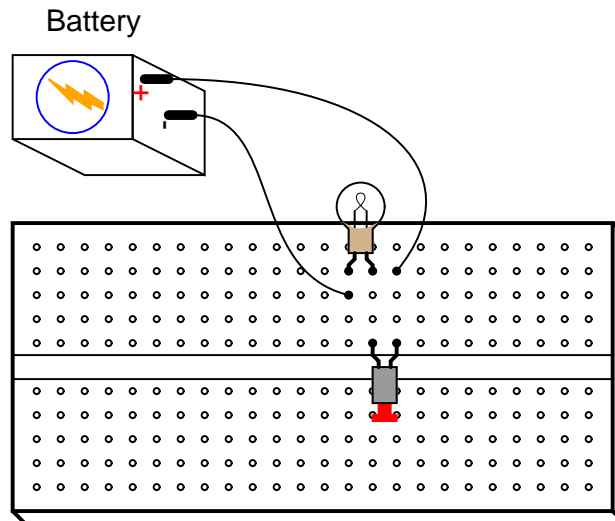

"Short circuit" caused
by breadboard interconnections

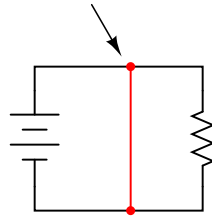

Follow-up question #1: explain what might happen if a large battery or high-current power supply were powering this short circuit.

Follow-up question #2: show how the single-resistor circuit *should* have been built on the breadboard so as to avoid a short circuit.

Notes

Notes 1

It might be helpful to show students what real pieces of wire look like, in order for them to better understand the nature of the problem. Most electrical wire is *insulated* in one form or another, and this insulation must not be removed (or "stripped") in order to establish bare metal-to-metal contact.

Notes 2

Be sure to inform your students that poor electrical connections, often with regard to plug-and-jack assemblies, are a *very* common source of failure in electrical and electronic systems.

Notes 3

Be sure to have a variety of terminal blocks available for your students to see and touch during discussion time. Terminal blocks are widely used in industrial applications, for making permanent and semi-permanent connections.

Notes 4

I'm not sure if there is a specific code or regulation governing the number of terminals connected to a terminal block, but the "no more than two wires per lug" rule makes good sense. That is, of course, unless two conductors stuffed in the same hole would exceed the maximum cross-sectional area limit of the block, then "no more than one wire" is the rule.

I have had the misfortune of seeing egregious violations of both rules in my work experience!

Notes 5

It would be good to have several sizes of wire nuts available in the classroom for your students to see and touch during discussion.

Notes 6

It should be noted that not all forms of soldering are "low temperature." Silver soldering, for example, takes place at much greater temperatures than regular electrical soldering. However, all soldering is a form of welding.

Notes 7

Be sure to have a variety of printed circuit boards available for your students to see and touch during discussion time. PCBs are widely used in all varieties of electronic applications, and are well suited for mass production manufacturing techniques.

Notes 8

Though wire-wrapping is not as prevalent now as it was a few decades ago, it still has merit for certain applications, notably prototyping. If possible, have some wire-wrapped circuit boards available to show your students during discussion time.

Notes 9

Discuss with your students the ideal resistance of an electrical connection, regardless of type (soldered, terminal strip, wire wrap, wire nut, crimp connector, etc.), and under what conditions you would test the resistance of an electrical connection.

Notes 10

It may be more difficult that it first appears to test for voltage across any single connection, if the wires are covered with insulation! Ask your students this question: if you test for voltage between two screws on a terminal strip, how many electrical connections are you actually measuring voltage across?

Notes 11

”Mapping” the holes on a solderless breadboard is a fun exercise to do in class with ohmmeters (or any other form of continuity indicator).

Notes 12

Solderless breadboards are extremely useful tools for prototyping circuits in a classroom/lab environment. Familiarity with their use is a virtual necessity for any modern electronics curriculum. That being said, it is important not to over-emphasize breadboards, though. I have seen some electronics courses where breadboards are the only form of circuit construction students ever use! This does not prepare them for challenges of the job, where breadboards are (rightfully) used only for prototyping.

In summary, use breadboards in your students’ labwork, *but not all the time*, or even most of the time!

Notes 13

Situations such as this are *very* common among new students! Be sure to discuss the significance of ”short circuits” as well as how to avoid them.