

## ELTR 120 (Semiconductors 1), section 1

### Recommended schedule

---

#### Day 1

Topics: *Semiconductor theory and PN junctions*

Questions: *1 through 20*

Lab Exercise: *Rectifier diode characteristics (question 91)*

---

#### Day 2

Topics: *Diodes and rectifier circuits*

Questions: *21 through 40*

Lab Exercise: *Full-wave, center-tap rectifier circuit (question 92)*

---

#### Day 3

Topics: *AC-DC power supply circuits and troubleshooting*

Questions: *41 through 60*

Lab Exercise: *Full-wave bridge rectifier circuit (question 93)*

---

#### Day 4

Topics: *Special diodes and zener voltage regulators*

Questions: *61 through 80*

Lab Exercise: *Zener diode voltage regulator circuit (question 94)*

---

#### Day 5

Topics: *Electron versus Conventional flow notation*

Questions: *81 through 90*

Lab Exercise: *LED current limiting (question 95)*

---

#### Day 6

Exam 1: *includes rectifier circuit performance assessment*

Project selection: *Initial project design checked by instructor and components selected (Dual output AC-DC power supply strongly recommended)*

Lab Exercise: *Work on project*

---

#### Troubleshooting practice problems

Questions: *97 through 106*

---

#### General concept practice and challenge problems

Questions: *107 through the end of the worksheet*

---

#### Impending deadlines

**Project due at end of ELTR120, Section 3**

Question 96: Sample project grading criteria

Skill standards addressed by this course section

---

EIA Raising the Standard: Electronics Technician Skills for Today and Tomorrow, June 1994

**D Technical Skills – Discrete Solid-State Devices**

- D.01 Demonstrate an understanding of the properties of semiconducting materials.
- D.02 Demonstrate an understanding of PN junctions.
- D.05 Demonstrate an understanding of special diodes and transistors. *Partially met – special diodes only.*
- D.06 Understand principles and operations of diode circuits.
- D.07 Fabricate and demonstrate diode circuits.
- D.08 Troubleshoot and repair diode circuits.

**E Technical Skills – Analog Circuits**

- E.07 Understand principles and operations of linear power supplies and filters.
- E.08 Fabricate and demonstrate linear power supplies and filters.
- E.09 Troubleshoot and repair linear power supplies and filters.

**B Basic and Practical Skills – Communicating on the Job**

- B.01 Use effective written and other communication skills. *Met by group discussion and completion of labwork.*
- B.03 Employ appropriate skills for gathering and retaining information. *Met by research and preparation prior to group discussion.*
- B.04 Interpret written, graphic, and oral instructions. *Met by completion of labwork.*
- B.06 Use language appropriate to the situation. *Met by group discussion and in explaining completed labwork.*
- B.07 Participate in meetings in a positive and constructive manner. *Met by group discussion.*
- B.08 Use job-related terminology. *Met by group discussion and in explaining completed labwork.*
- B.10 Document work projects, procedures, tests, and equipment failures. *Met by project construction and/or troubleshooting assessments.*

**C Basic and Practical Skills – Solving Problems and Critical Thinking**

- C.01 Identify the problem. *Met by research and preparation prior to group discussion.*
- C.03 Identify available solutions and their impact including evaluating credibility of information, and locating information. *Met by research and preparation prior to group discussion.*
- C.07 Organize personal workloads. *Met by daily labwork, preparatory research, and project management.*
- C.08 Participate in brainstorming sessions to generate new ideas and solve problems. *Met by group discussion.*

**D Basic and Practical Skills – Reading**

- D.01 Read and apply various sources of technical information (e.g. manufacturer literature, codes, and regulations). *Met by research and preparation prior to group discussion.*

**E Basic and Practical Skills – Proficiency in Mathematics**

- E.01 Determine if a solution is reasonable.
- E.02 Demonstrate ability to use a simple electronic calculator.
- E.05 Solve problems and [sic] make applications involving integers, fractions, decimals, percentages, and ratios using order of operations.
- E.06 Translate written and/or verbal statements into mathematical expressions.
- E.09 Read scale on measurement device(s) and make interpolations where appropriate. *Met by oscilloscope usage.*
- E.12 Interpret and use tables, charts, maps, and/or graphs.
- E.13 Identify patterns, note trends, and/or draw conclusions from tables, charts, maps, and/or graphs.
- E.15 Simplify and solve algebraic expressions and formulas.
- E.16 Select and use formulas appropriately.
- E.17 Understand and use scientific notation.

**F Basic and Practical Skills – Proficiency in Physics**

- F.04 Understand principles of electricity including its relationship to the nature of matter.

## Common areas of confusion for students

---

### Difficult concept: *Quantum physics.*

One of my "pet peeves" regarding introductory electronics textbooks is that they commonly attempt to explain the workings of PN semiconductor junctions while holding to Rutherford's obsolete planetary model of the atom. Electrons *do not* circle atomic nuclei like little planets, free to travel arbitrary orbits. Instead, they may only assume a limited number of energy states, necessitating "quantum leaps" to change between them. It is this discrete behavior that makes semiconductor devices possible. Thankfully, there are a great many plainly-understandable resources on the internet and in some modern textbooks explaining this, and the relationship to current in semiconductor materials.

### Difficult concept: *RMS versus peak and average measurements.*

The very idea of assigning a fixed number for AC voltage or current that (by definition) constantly changes magnitude and direction seems strange. Consequently, there is more than one way to do it. We may assign that value according to the *highest* magnitude reached in a cycle, in which case we call it the *peak* measurement. We may mathematically integrate the waveform over time to figure the mean magnitude, in which case we call it the *average* measurement. Or we may figure out what level of DC (voltage or current) causes the exact same amount of average power to be dissipated by a standard resistive load, in which case we call it the *RMS* measurement. One common mistake here is to think that the relationship between RMS, average, and peak measurements is a matter of fixed ratios. The number "0.707" is memorized by every beginning electronics student as the ratio between RMS and peak, but what is commonly overlooked is that this particular ratio holds true *for perfect sine-waves only!* A wave with a different shape will have a different mathematical relationship between peak and RMS values.

### Difficult concept: *Zener diode voltage regulator operation.*

Zener diode voltage regulators are often difficult for students to grasp because the diodes themselves are so highly nonlinear. One cannot apply any variation of Ohm's Law to a zener diode, and this makes the circuit seem intractable at first glance. A "trick" I often apply to the circuits is to first imagine the zener diode failed open and see whether or not the voltage across the (open) diode terminals exceeds the diode's zener voltage rating. If so, then you know the diode will actually be clipping (limiting) voltage to that rated value, and you may proceed with your circuit analysis assuming that much voltage across any components parallel to the zener diode. If not, you know the diode will not be conducting current, and you may treat it as if it is truly failed open!

### Difficult concept: *Fourier analysis.*

No doubt about it, Fourier analysis is a strange concept to understand. Strange, but incredibly useful! While it is relatively easy to grasp the principle that we may create a square-shaped wave (or any other symmetrical waveshape) by mixing together the right combinations of sine waves at different frequencies and amplitudes, it is far from obvious that *any* periodic waveform may be decomposed into a series of sinusoidal waves the same way. The practical upshot of this is that it is possible to consider very complex waveshapes as being nothing more than a bunch of sine waves added together. Since sine waves are easy to analyze in the context of electric circuits, this means we have a way of simplifying what would otherwise be a dauntingly complex problem: analyzing how circuits respond to non-sinusoidal waveforms.

The actual "nuts and bolts" of Fourier analysis is highly mathematical and well beyond the scope of this course. Right now all I want you to grasp is the concept and significance of equivalence between arbitrary waveshapes and series of sine waves.

A great way to experience this equivalence is to play with a digital oscilloscope with a built-in spectrum analyzer. By introducing different wave-shape signals to the input and switching back and forth between the time-domain (scope) and frequency-domain (spectrum) displays, you may begin to see patterns that will enlighten your understanding.

**Common mistake:** *Failing to respect shock hazard of line-powered circuits.*

Students should review the principles of electrical safety prior to building the dual-output AC/DC power supply. Unlike nearly all the previous labs which harbored little or no shock hazard, this project can shock you. The most important rule you can follow is to simply unplug the circuit from the AC line before reaching toward any part of the circuit with your hand or with a conductive tool. The only things you should touch a live circuit with are test probes for measurement equipment! Another common mistake is to fail to remove conductive jewelry (bracelets, rings, etc.) prior to working with line-powered circuits.

## Questions

---

### Question 1

In any electrically conductive substance, what are *charge carriers*? Identify the charge carriers in metallic substances, semiconducting substances, and conductive liquids.

[file 00904](#)

---

### Question 2

A common conceptual model of electrons within atoms is the "planetary" model, with electrons depicted as orbiting satellites whirling around the "planet" of the nucleus. The physicist Ernest Rutherford is known as the inventor of this atomic model.

A major improvement over this conceptual model of the atom came from Niels Bohr, who introduced the idea that electrons inhabited "stationary states" around the nucleus of an atom, and could only assume a new state by way of a *quantum leap*: a sudden "jump" from one energy level to another.

What led Bohr to his radical proposal of "quantum leaps" as an alternative to Rutherford's model? What experimental evidence led scientists to abandon the old planetary model of the atom, and how does this evidence relate to modern electronics?

[file 00900](#)

---

### Question 3

In solitary atoms, electrons are free to inhabit only certain, discrete energy states. However, in solid materials where there are many atoms in close proximity to each other, *bands* of energy states form. Explain what it means for there to be an energy "band" in a solid material, and why these "bands" form.

[file 00901](#)

---

#### Question 4

Engineers and scientists often use *energy band diagrams* to graphically illustrate the energy levels of electrons in different substances. Electrons are shown as solid dots:

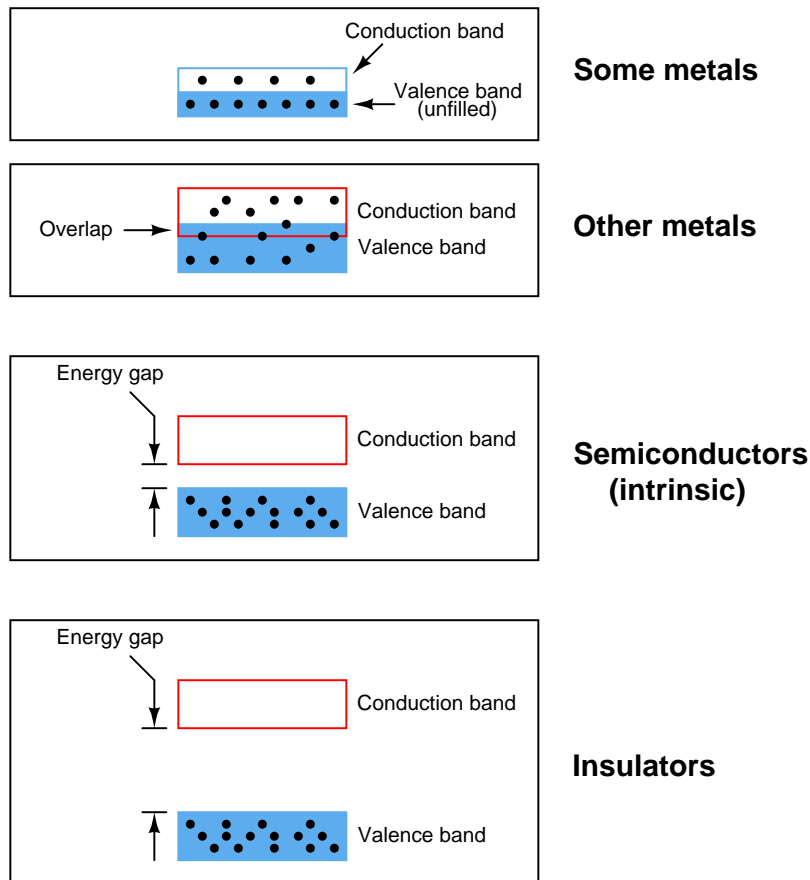

Based on these diagrams, answer the following questions:

- Which type of material is the best conductor of electricity, and *why*?
- Which type of material is the worst conductor of electricity, and *why*?

[file 00716](#)

---

#### Question 5

Sadly, many introductory textbooks oversimplify the definition of a *semiconductor* by declaring them to be substances whose atoms contain four valence-shell (outer level) electrons. Silicon and germanium are traditionally given as the two major semiconductor materials used.

However, there is more to a "semiconductor" than this simple definition. Take for instance the element carbon, which also has four valence electrons just like atoms of silicon and germanium. But not all forms of carbon are semiconducting: diamond is (at high temperatures), but graphite is not, and microscopic tubes known as "carbon nanotubes" may be made either conducting or semiconducting just by varying their diameter and "twist rate."

Provide a more accurate definition of what makes a "semiconductor," based on electron bands. Also, name some other semiconducting substances.

[file 02002](#)

Question 6

If a pure ("intrinsic") semiconductor material is heated, the thermal energy liberates some valence-band electrons into the conduction band. The vacancies left behind in the valence band are called *holes*:

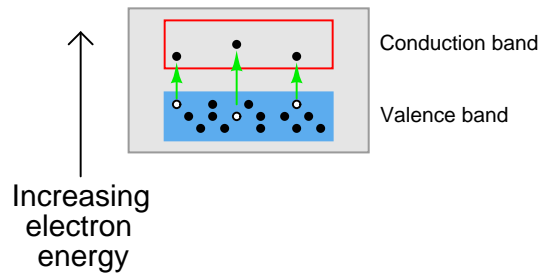

If an electrical voltage is applied across the heated semiconducting substance, with positive on the left and negative on the right, what will this do to the energy bands, and how will this affect both the electrons and the holes?

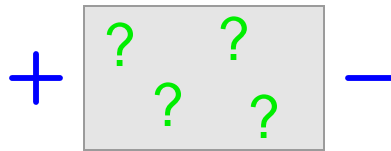

file 00903

Question 7

In perfectly pure ("intrinsic") semiconductors, the only way charge carriers can exist is for valence electrons to "leap" into the conduction band with the application of sufficient energy, leaving a *hole*, or vacancy, behind in the valence band:

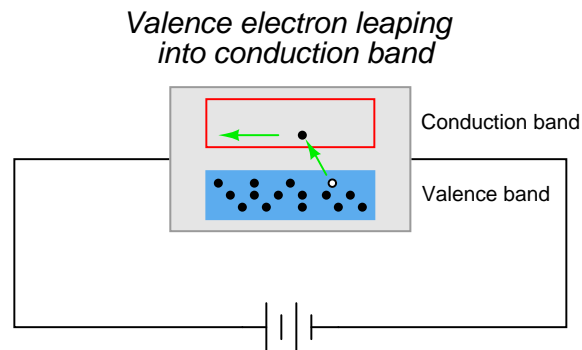

With sufficient thermal energy, these electron-hole pairs will form spontaneously. At room temperature, however, this activity is slight.

We may greatly enhance charge carrier formation by adding specific impurities to the semiconducting material. The energy states of atoms having different electron configurations do not precisely "blend" with the electron bands of the parent semiconductor crystal, causing additional energy levels to form.

Some types of impurities will cause extra *donor* electrons to lurk just beneath the main conduction band of the crystal. These types of impurities are called *pentavalent*, because they have 5 valence electrons per atom rather than 4 as the parent substance typically possesses:

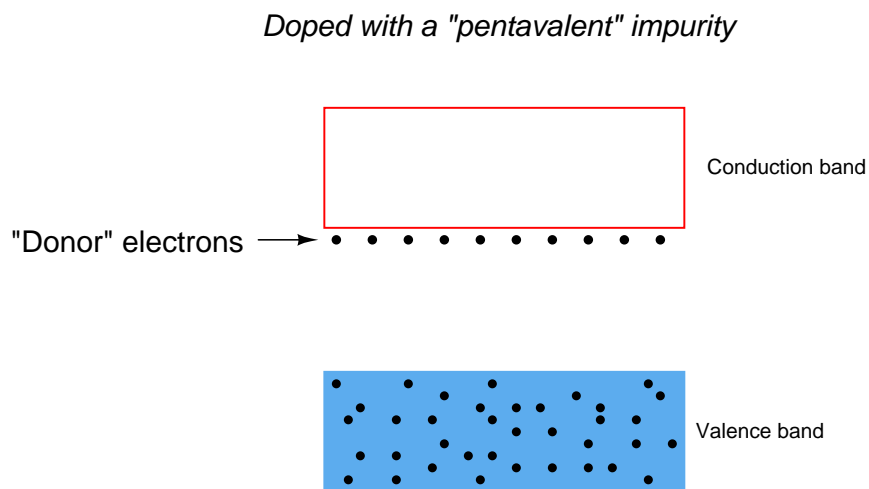

Other types of impurities will cause vacant electron levels (*acceptor* "holes") to form just above the main valence band of the crystal. These types of impurities are called *trivalent*, because they have 3 valence electrons per atom instead of 4:



*Doped with a "trivalent" impurity*

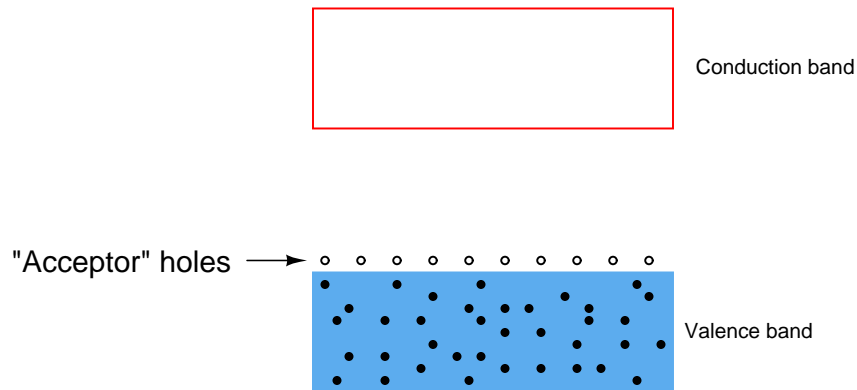

Compare the ease of forming free (conduction-band) electrons in a semiconductor material having lots of "donor" electrons, against that of an intrinsic (pure) semiconductor material. Which type of material will be more electrically conductive?

Likewise, compare the ease of forming valence-band holes in a semiconductor material having lots of "acceptor" holes, against that of an intrinsic (pure) semiconductor material. Which type of material will be more electrically conductive?

[file 00902](#)

---

Question 8

What type of substance(s) must be added to an intrinsic semiconductor in order to produce "donor" electrons? When this is done, how do we denote this type of "doped" semiconducting substance?

Likewise, what type of substance(s) must be added to an intrinsic semiconductor in order to produce "acceptor" holes? When this is done, how do we denote this type of "doped" semiconducting substance?

[file 00907](#)

---

Question 9

In extrinsic semiconductors, what are *majority carriers* and how do they differ from *minority carriers*?

[file 00912](#)

---

Question 10

Explain what the *Fermi level* is for a substance.

[file 02003](#)

Question 11

Shown here are two energy diagrams: one for a "P" type semiconducting material and another for an "N" type.

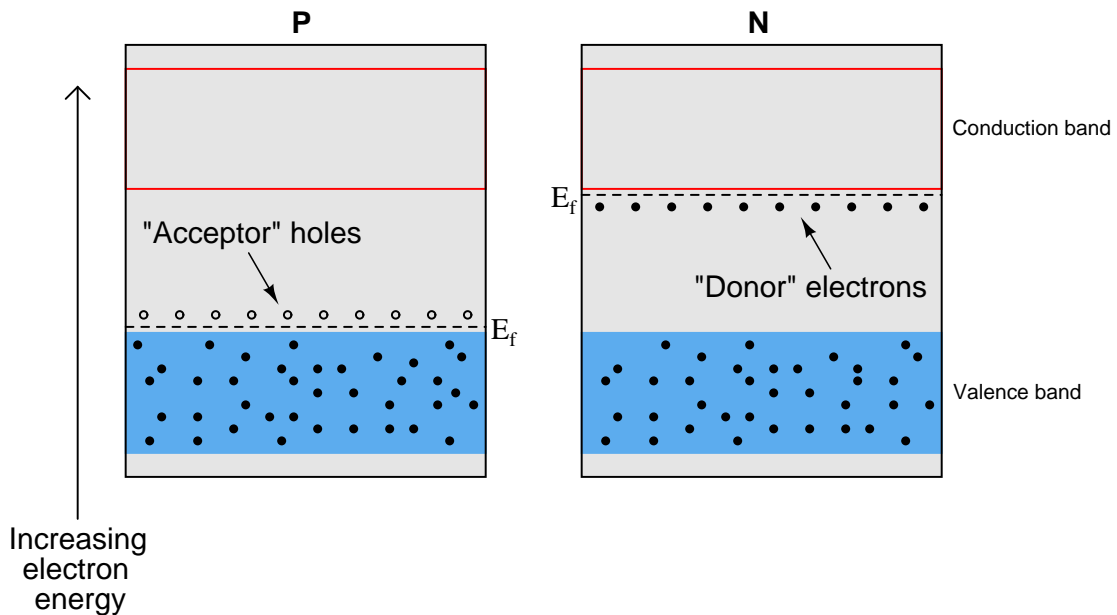

Next is an energy diagram showing the *initial* state when these two pieces of semiconducting material are brought into contact with each other. This is known as a *flatband diagram*:

*"Flatband" diagram -- temporary state!*

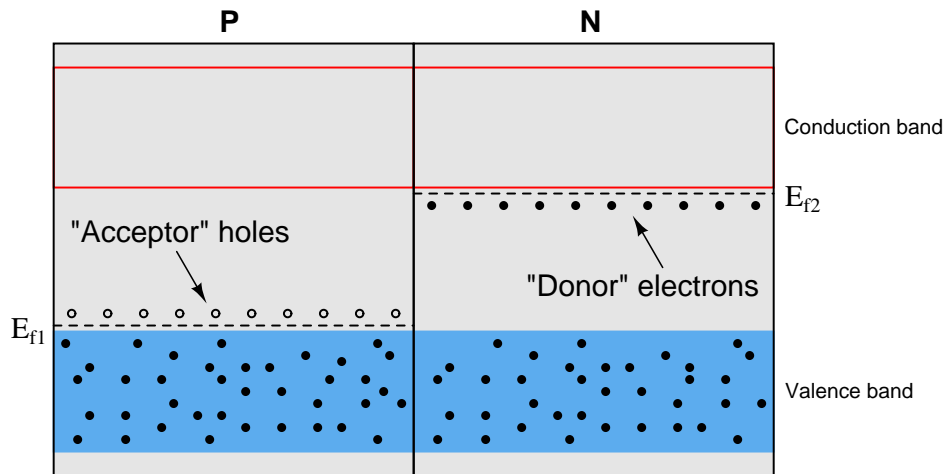

The state represented by the "flatband" diagram is most definitely a temporary one. The two different Fermi levels are incompatible with one another in the absence of an external electric field.

Draw a new energy diagram representing the final energy states after the two Fermi levels have equalized.

*Note:  $E_f$  represents the Fermi energy level, and not a voltage. In physics,  $E$  always stands for energy and  $V$  for electric potential (voltage).*

[file 00906](#)

---

Question 12

What happens to the thickness of the depletion region in a PN junction when an external voltage is applied to it?

[file 00909](#)

---

Question 13

Draw an energy diagram for a PN semiconductor junction under the influence of a *reverse* external voltage.

[file 00910](#)

---

Question 14

Draw an energy diagram for a PN semiconductor junction under the influence of a *forward* external voltage.

[file 02005](#)

---

Question 15

Draw an energy diagram for a PN semiconductor junction showing the motion of electrons and holes conducting an electric current.

[file 02006](#)

---

Question 16

Most introductory textbooks will tell you that a silicon PN junction drops 0.7 volts when forward-biased, and a germanium PN junction drops 0.3 volts when forward biased. Design a circuit that tests the "forward voltage" ( $V_F$ ) of a PN-junction diode, so you may measure the voltage yourself, without the use of a special diode-testing meter.

[file 00711](#)

---

Question 17

If a semiconductor PN junction is reverse-biased, ideally no continuous current will go through it. However, in real life there will be a small amount of reverse-bias current that goes through the junction. How is this possible? What allows this reverse current to flow?

[file 00913](#)

---

---

Question 18

The relationship between voltage and current for a PN junction is described by this equation, sometimes referred to as the "diode equation," or "Shockley's diode equation" after its discoverer:

$$I_D = I_S(e^{\frac{qV_D}{NkT}} - 1)$$

Where,

$I_D$  = Current through the PN junction, in amps

$I_S$  = PN junction saturation current, in amps (typically 1 picoamp)

$e$  = Euler's number  $\approx 2.718281828$

$q$  = Electron unit charge,  $1.6 \times 10^{-19}$  coulombs

$V_D$  = Voltage across the PN junction, in volts

$N$  = Nonideality coefficient, or emission coefficient (typically between 1 and 2)

$k$  = Boltzmann's constant,  $1.38 \times 10^{-23}$

$T$  = Junction temperature, degrees Kelvin

At first this equation may seem very daunting, until you realize that there are really only three variables in it:  $I_D$ ,  $V_D$ , and  $T$ . All the other terms are constants. Since in most cases we assume temperature is fairly constant as well, we are really only dealing with two variables: diode current and diode voltage. Based on this realization, re-write the equation as a proportionality rather than an equality, showing how the two variables of diode current and voltage relate:

$$I_D \propto \dots$$

Based on this simplified equation, what would an I/V graph for a PN junction look like? How does this graph compare against the I/V graph for a resistor?

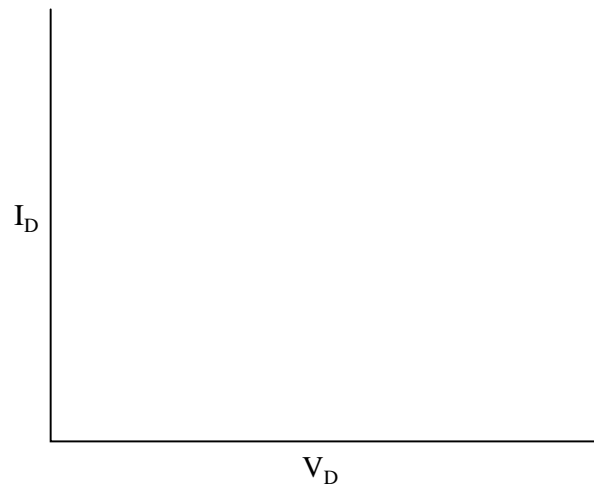

file 00712

---

Question 19

In order to simplify analysis of circuits containing PN junctions, a "standard" forward voltage drop is assumed for any conducting junction, the exact figure depending on the type of semiconductor material the junction is made of.

How much voltage is assumed to be dropped across a conducting *silicon* PN junction? How much voltage is assumed for a forward-biased *germanium* PN junction? Identify some factors that cause the real forward voltage drop of a PN junction to deviate from its "standard" figure.

[file 00898](#)

---

Question 20

Measure the forward voltage drop of a silicon rectifying diode, such as a model 1N4001. How close is the measured forward voltage drop to the "ideal" figure usually assumed for silicon PN junctions? What happens when you increase the temperature of the diode by holding on to it with your fingers? What happens when you decrease the temperature of the diode by touching an ice cube to it?

[file 00714](#)

---

Question 21

How is it possible to determine the polarity of a rectifying diode (which terminal is the anode, and which terminal is the cathode) from its physical appearance?

[file 00919](#)

---

Question 22

The "1N400x" series of rectifying diodes are very popular for low-current applications. By "1N400x," I mean the 1N4001, 1N4002, 1N4003, . . . 1N4007. Only one parameter differs between these different diode models. What parameter is this, and what is its significance?

[file 00921](#)

---

Question 23

Describe the operation of this diode testing circuit:

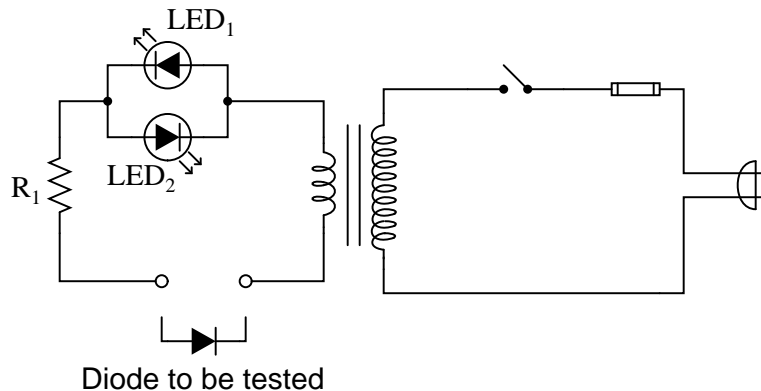

Identify what the two light-emitting diodes (LEDs) will do when testing these three types of diodes:

- Good diode
- Diode failed shorted
- Diode failed open

[file 00918](#)

---

Question 24

A useful piece of test equipment for semiconductor components is a *curve tracer*, used to produce current/voltage graphs for a component being tested. The graphs are typically displayed on an oscilloscope screen. Here is a very simple curve tracer circuit, designed to be used with an oscilloscope in X-Y mode:

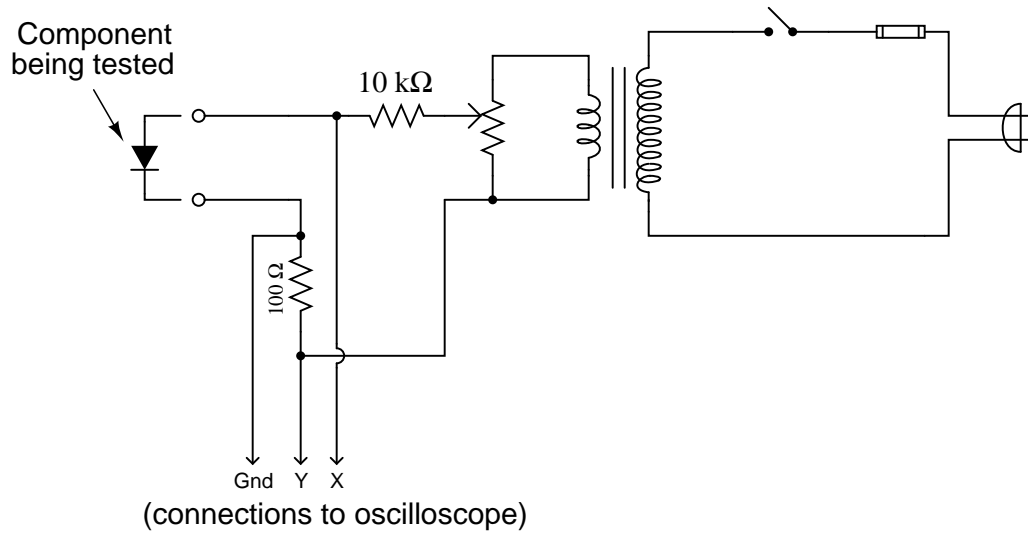

Describe what type of trace would be drawn by this circuit on an oscilloscope screen if a *resistor* was being tested. Then, show the trace for a normal rectifying diode.

[file 00923](#)

---

Question 25

Suppose we have an application where a DC generator provides power to charge a secondary-cell battery:

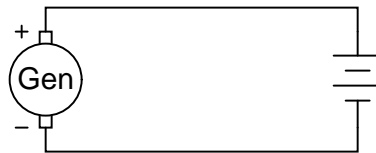

The only problem with this setup is, the generator tries to act as a motor when the engine turning it is shut off, drawing power from the battery and discharging it. How could we use a rectifying diode to prevent this from happening?

[file 00947](#)

---

Question 26

What could you do if you had an application for a rectifying diode that required a forward current rating of 2.5 amps, but you only had model 1N4001 diodes available to use? How could you use multiple 1N4001 rectifying diodes to handle this much current?

[file 00948](#)

---

Question 27

Suppose you were building a simple half-wave rectifier circuit for a 480 volt AC source. The diode needs to withstand the full (peak) voltage of this AC source every other half-cycle of the waveform, or else it will fail. The bad news is, the only diodes you have available for building this rectifier circuit are model 1N4002 diodes.

Describe how you could use multiple 1N4002 rectifying diodes to handle this much reverse voltage.

[file 00949](#)

---

Question 28

Find one or two real diodes and bring them with you to class for discussion. Identify as much information as you can about your diodes prior to discussion:

- Polarity (which terminal is cathode and which is anode)
- Forward voltage drop
- Continuous current rating
- Surge current rating
- Continuous power rating

[file 01162](#)

---

Question 29

What would this permanent-magnet DC motor do, if powered by a source of AC voltage?

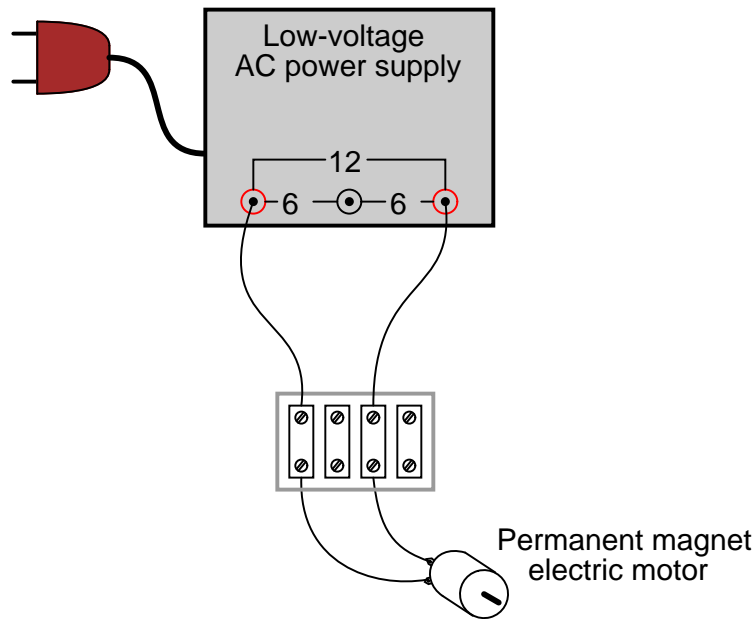

[file 00778](#)

---

Question 30

What would this permanent-magnet DC motor do, if powered by the following circuit?

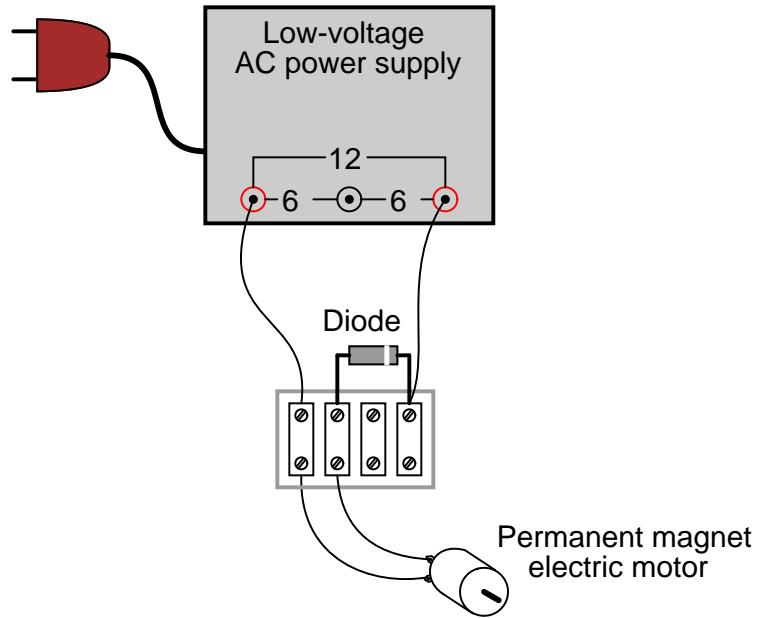

file 00779

---

Question 31

What would this permanent-magnet DC motor do, if powered by the following circuit?

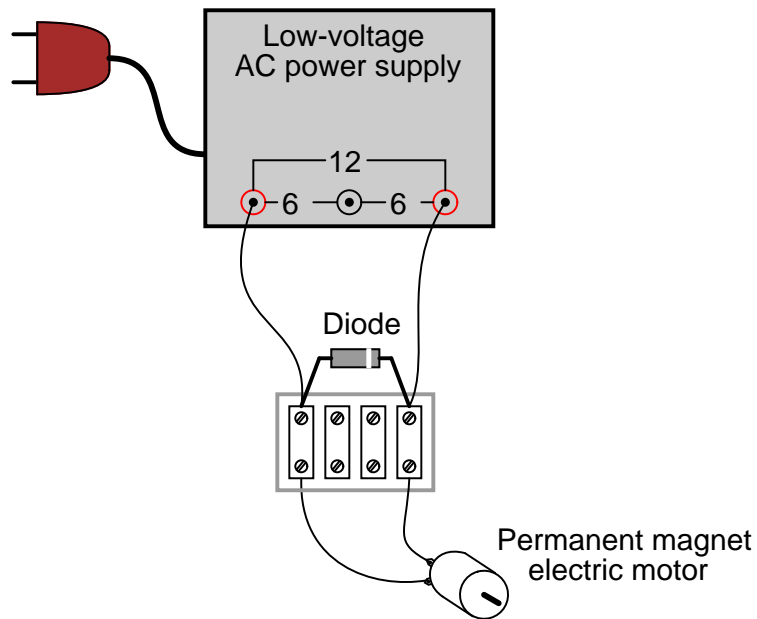

file 00780



---

Question 32

Some inexpensive household lamps use a diode to achieve two-position light control (dim and bright):

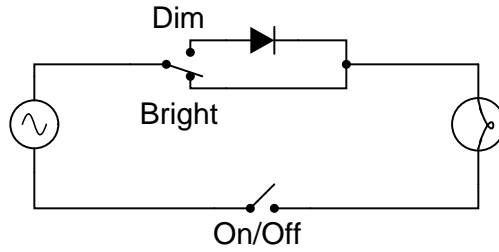

Explain how this circuit is able to make the light bulb glow brighter and dimmer.  
[file 00782](#)

---

Question 33

Trace the flow of all currents in this half of the AC cycle (note the polarity symbols near the transformer's primary winding terminals):

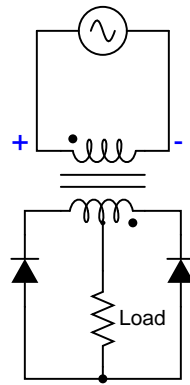

Now, trace the flow of all currents in the other half of the AC cycle (note the polarity symbols near the transformer's primary winding terminals):

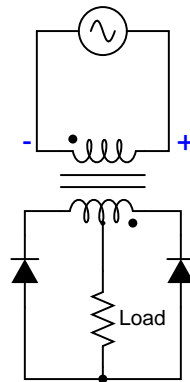

Also, determine the polarity of DC voltage across the load resistor.  
[file 00781](#)

Question 34

In this rectifier circuit, the output voltage is less than half of the secondary winding's rated voltage (12 volts). Why is this?

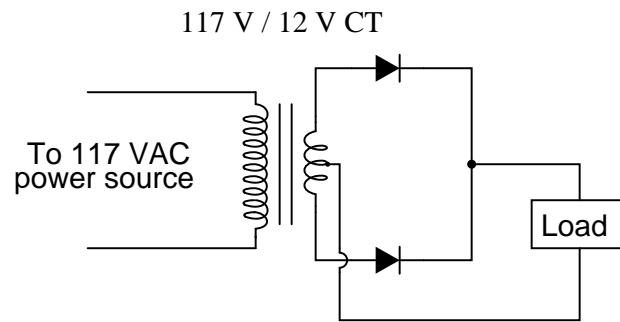

Also, determine whether this is a *half-wave* or a *full-wave* rectifier circuit, and explain your answer.  
[file 00783](#)

Question 35

A very common form of full-wave rectifier circuit is the *bridge rectifier*. Typically, it is drawn as a "diamond" of four diodes:

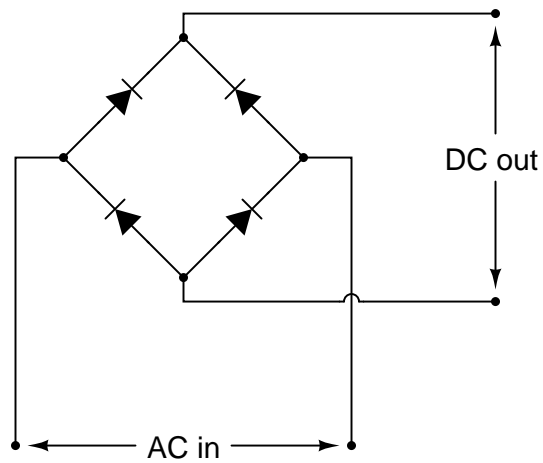

Draw the connections in this illustration to form a bridge rectifier circuit, receiving power from the transformer and delivering power to the light bulb:

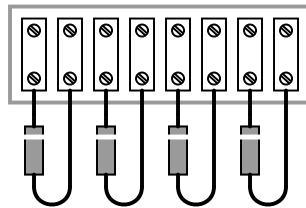
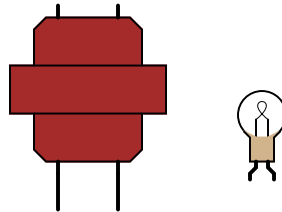

[file 00784](#)

Question 36

Determine the approximate amount of voltage that each voltmeter in this circuit will indicate:

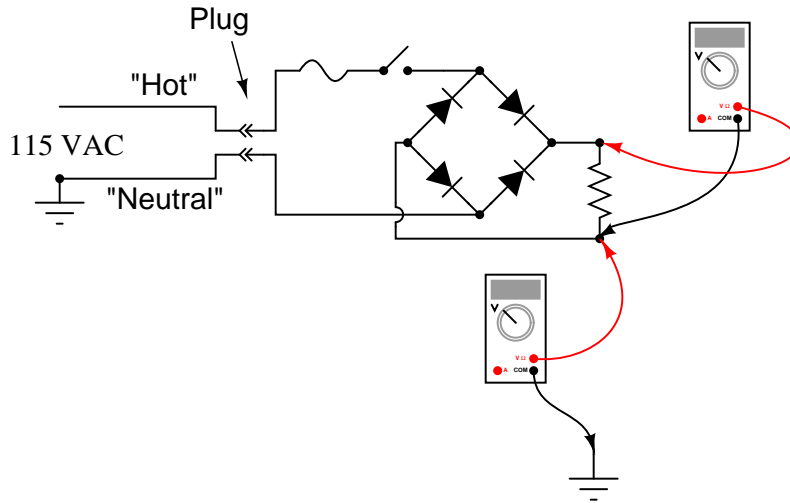

file 00786

### Question 37

A technician decides to measure the output voltage of a bridge rectifier circuit using an oscilloscope. This particular bridge rectifier is the front-end of a *switching power supply circuit*, and directly rectifies the incoming 120 volt AC power, with no transformer:

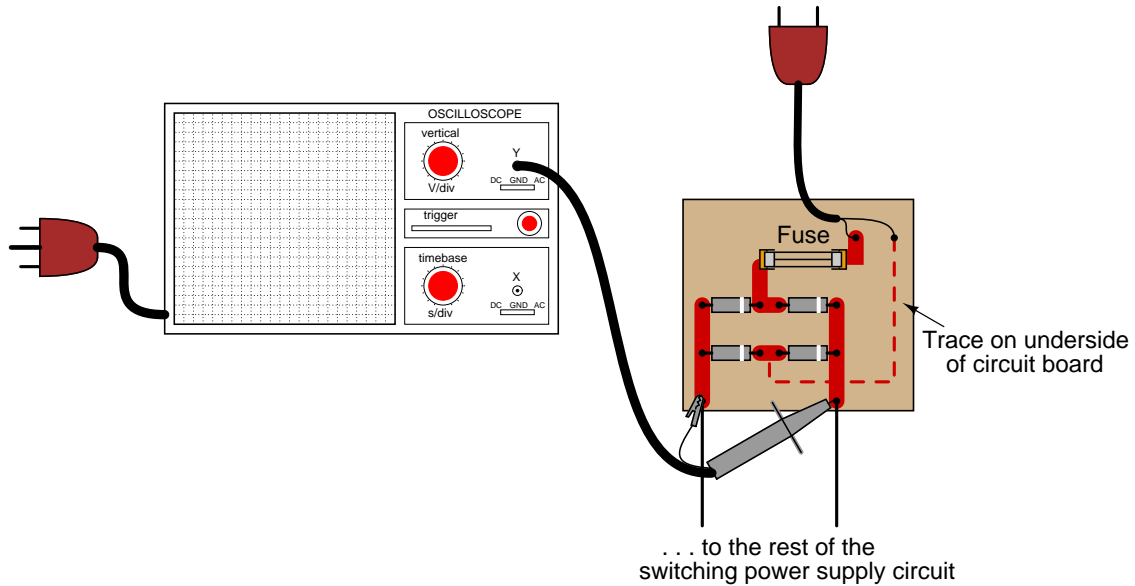

However, the technician is surprised to find that the fuse blows every time she turns the power on to the circuit. When the oscilloscope is disconnected from the circuit, the fuse does not blow, and everything works fine. What is wrong? Why does the oscilloscope cause a fault in the circuit?

Here is another interesting piece of information: if just the probe tip is touched to one of the rectifier circuit's output terminals, the oscilloscope shows a half-wave rectified waveform, without the ground clip being connected to anything!

[file 00787](#)

Question 38

Power rectifier circuits are often classified according to their number of *phases*, *ways*, and *pulses*. Match the following rectifier circuits to the Phase/Way/Pulse labels given in this illustration:

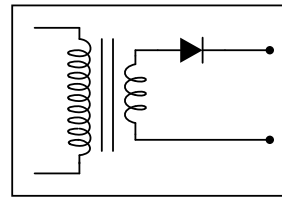
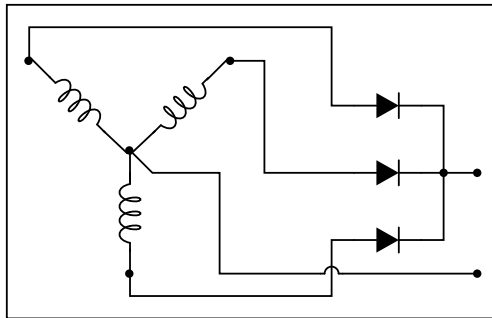
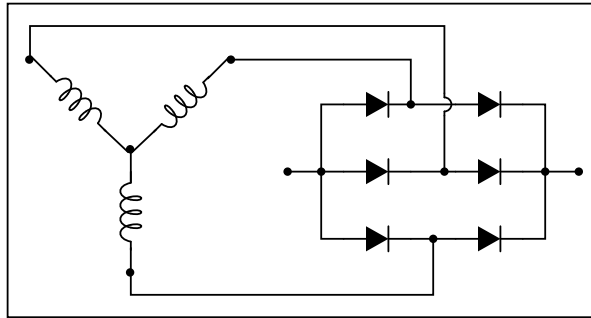
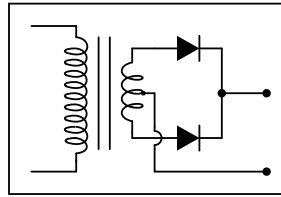
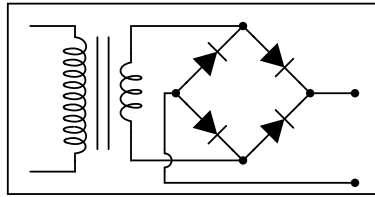

3Ph2W6P

1Ph1W2P

1Ph1W1P

1Ph2W2P

3Ph1W3P

file 00785

Question 39

*Bipolar transistors* are extremely useful devices, allowing a small electric current to control the flow of a much larger electric current:

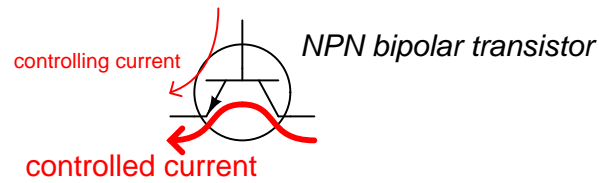

(Direction of current shown using "conventional" flow)

These devices would be even more useful to us if they were able to control alternating current (AC), but they cannot. Bipolar transistors are polarized (one-way-only) devices.

This fact does not prevent us from using bipolar transistors to control AC. We just have to be clever about how we do it:

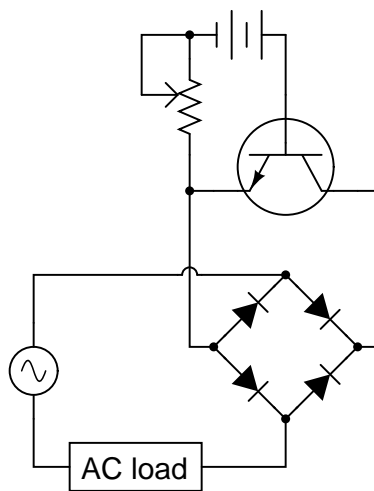

Explain how this circuit functions. How is the transistor (a DC-only device) able to control alternating current (AC) through the load?

[file 00777](#)

---

Question 40

Suppose you need to build a full-wave bridge rectifier with a current rating of 2.5 amps, but only have model 1N4001 diodes to build it with. Draw a schematic diagram of the circuit, showing how multiple 1N4001 diodes could be connected together to accomplish this:

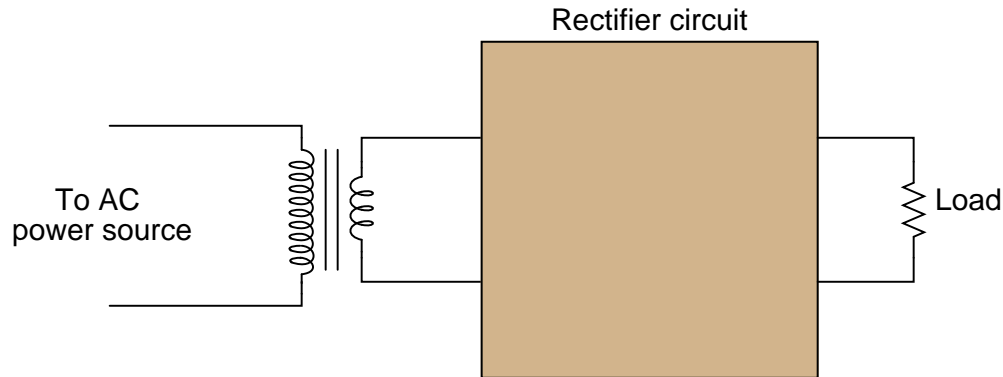

[file 00946](#)

---

Question 41

AC-DC power supply circuits are one of the most common circuit configurations in electronic systems. Though designs may vary, the task of converting AC power to DC power is vital in the functioning of a great many electronic devices.

Why is this? What is it about this kind of circuit that makes it such a necessary part of many electronic systems?

[file 00788](#)

---

Question 42

Although not a popular design, some power supply circuits are transformerless. Direct rectification of AC line power is a viable option in some applications:

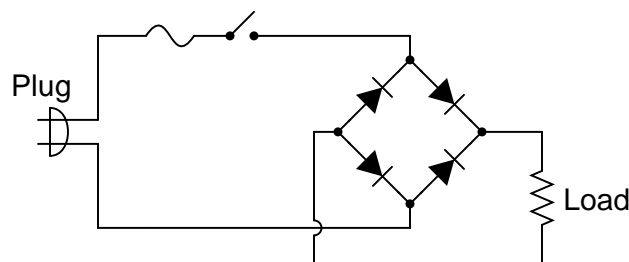

However, this form of AC-to-DC power conversion has some significant limits. Explain why most power supply circuits utilize a transformer instead of directly rectifying the line power as this circuit does.

[file 02016](#)



Question 43

An essential part of an AC-DC power supply circuit is the *filter*, used to separate the residual AC (called the "ripple" voltage) from the DC voltage prior to output. Here are two simple AC-DC power supply circuits, one without a filter and one with:

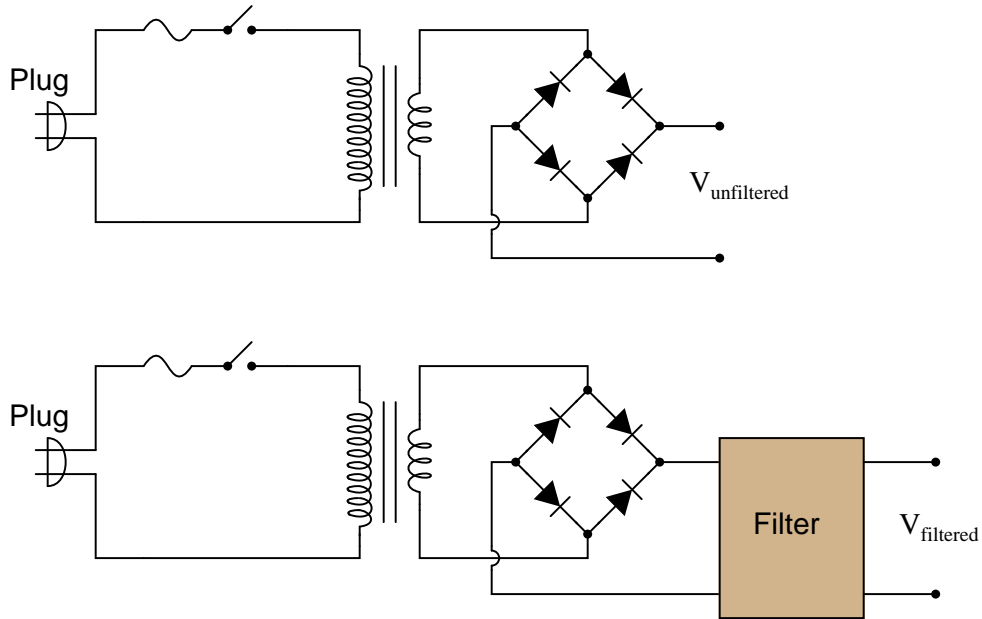

Draw the respective output voltage waveforms of these two power supply circuits ( $V_{unfiltered}$  versus  $V_{filtered}$ ). Also identify the type of filter circuit needed for the task (low pass, high pass, band pass, or band stop), and explain why that type of filter circuit is needed.

file 00789

Question 44

Suppose a technician measures the voltage output by an AC-DC power supply circuit:

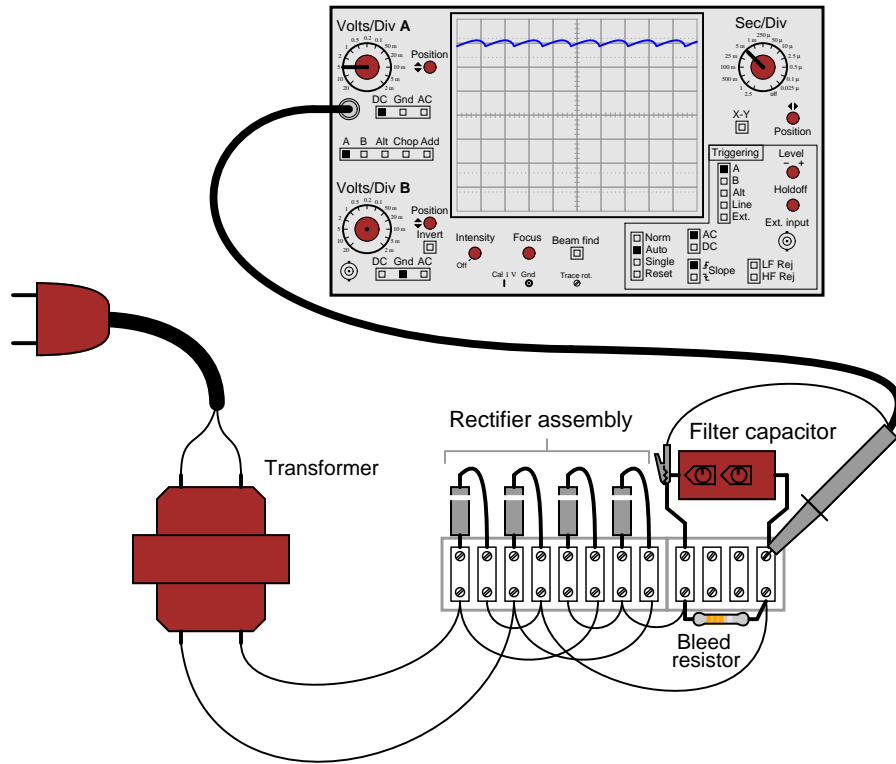

The waveform shown by the oscilloscope is mostly DC, with just a little bit of AC "ripple" voltage appearing as a ripple pattern on what would otherwise be a straight, horizontal line. This is quite normal for the output of an AC-DC power supply.

Suppose we wished to take a closer view of this "ripple" voltage. We want to make the ripples more pronounced on the screen, so that we may better discern their shape. Unfortunately, though, when we decrease the number of volts per division on the "vertical" control knob to magnify the vertical amplification of the oscilloscope, the pattern completely disappears from the screen!

Explain what the problem is, and how we might correct it so as to be able to magnify the ripple voltage waveform without having it disappear off the oscilloscope screen.

[file 00539](#)

---

Question 45

Observe the following two waveforms, as represented on an oscilloscope display measuring output voltage of a filtered power supply:

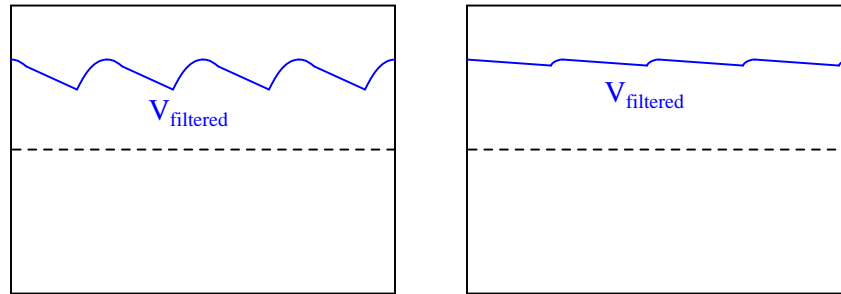

If both of these waveforms were measured on the same power supply circuit, at different times, determine which waveform was measured during a period of heavier "loading" (a "heavier" load being defined as a load drawing *greater* current).

[file 00792](#)

---

Question 46

What does it mean if a power supply has a DC output with 5% ripple?

[file 02013](#)

---

Question 47

What parameters determine the *frequency* of a power supply's ripple voltage?

[file 02014](#)

---

Question 48

Suppose a power supply is energized by an AC source of 119 V RMS. The transformer step-down ratio is 8:1, it uses a full-wave bridge rectifier circuit with silicon diodes, and the filter is nothing but a single electrolytic capacitor. Calculate the unloaded DC output voltage for this supply (assume 0.7 volts drop across each diode). Also, write an equation solving for DC output voltage ( $V_{out}$ ), given all these parameters.

[file 00798](#)

---

Question 49

What does it mean if a power supply exhibits 2% voltage regulation?

[file 02015](#)

---

Question 50

What will be the consequence of one diode failing open in the bridge rectifier of a single-phase power supply?

[file 00791](#)

---

Question 51

Suppose you suspected a failed-open diode in this power supply circuit. Describe how you could detect its presence without using an oscilloscope:

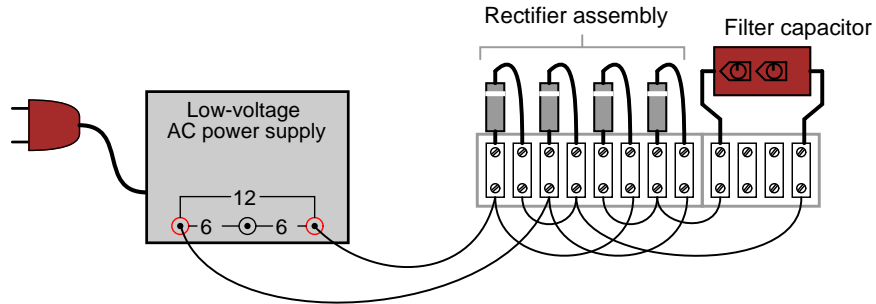

Incidentally, the "low voltage AC power supply" is nothing more than a step-down transformer with a center-tapped secondary winding.

[file 00794](#)

---

Question 52

A student learns that a rectifier circuit is often followed by a *low-pass filter* circuit in an AC-DC power supply to reduce "ripple" voltage on the output. Looking over his notes from AC theory, the student proceeds to build this power supply circuit complete with a low-pass filter at the output:

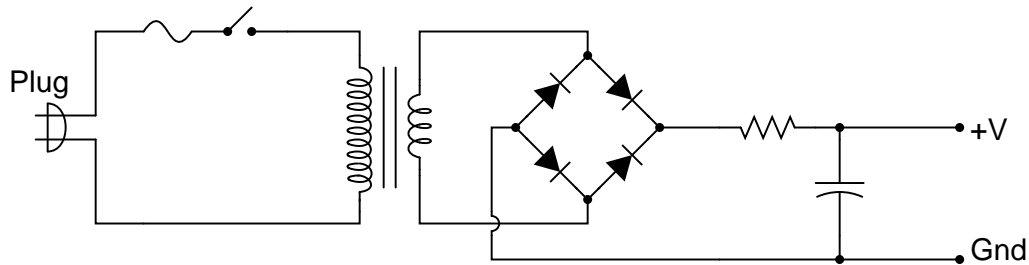

While this design will work, there are better filter configurations for this application. Describe the limitations of the circuit shown, and explain how some of the other filters would do a better job.

[file 00790](#)

Question 53

Identify the voltages that are *supposed* to appear between the listed test points:

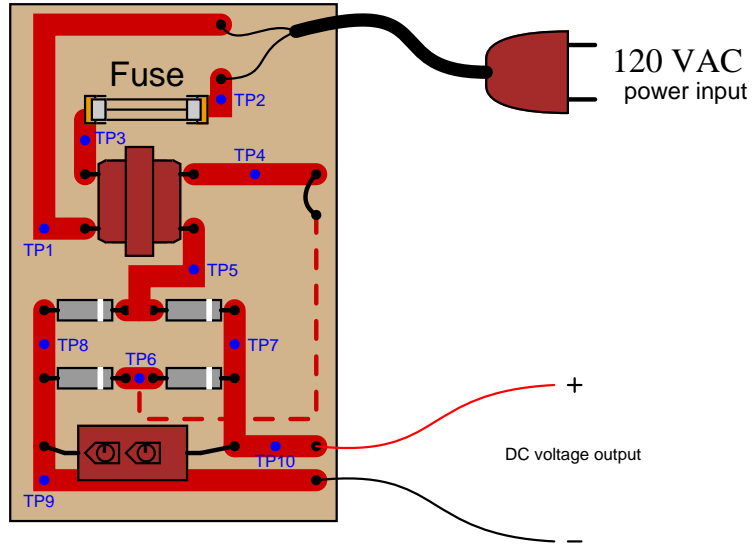

1.  $V_{TP1-TP2} =$
2.  $V_{TP1-TP3} =$
3.  $V_{TP2-TP3} =$
4.  $V_{TP4-TP5} =$
5.  $V_{TP5-TP6} =$
6.  $V_{TP7-TP8} =$
7.  $V_{TP9-TP10} =$

Assume that the power transformer has a step-down ratio of 9.5:1.  
file 02008

Question 54

A technician is troubleshooting a power supply circuit with no DC output voltage. The output voltage is supposed to be 15 volts DC:

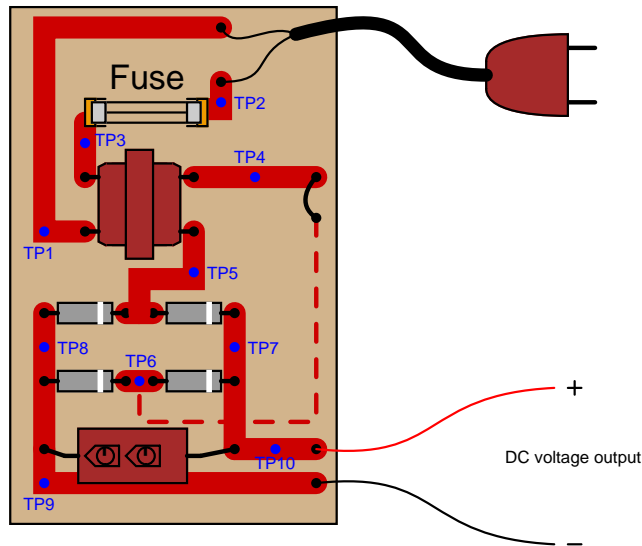

The technician begins making voltage measurements between some of the test points (TP) on the circuit board. What follows is a sequential record of his measurements:

1.  $V_{TP9-TP10} = 0$  volts DC
2.  $V_{TP8-TP7} = 0$  volts DC
3.  $V_{TP8-TP5} = 0$  volts DC
4.  $V_{TP6-TP7} = 0$  volts DC
5.  $V_{TP4-TP5} = 0$  volts AC
6.  $V_{TP1-TP3} = 0$  volts AC
7.  $V_{TP1-TP2} = 116$  volts AC

Based on these measurements, what do you suspect has failed in this supply circuit? Explain your answer. Also, critique this technician's troubleshooting technique and make your own suggestions for a more efficient pattern of steps.

file 00795

Question 55

A technician is troubleshooting a power supply circuit with no DC output voltage. The output voltage is supposed to be 15 volts DC:

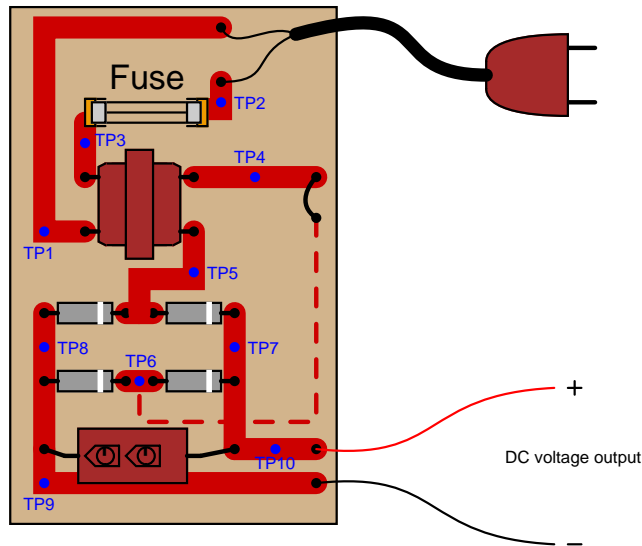

The technician begins making voltage measurements between some of the test points (TP) on the circuit board. What follows is a sequential record of her measurements:

1.  $V_{TP1-TP2} = 118$  volts AC
2.  $V_{TP3-TP2} = 0$  volts AC
3.  $V_{TP1-TP3} = 118$  volts AC
4.  $V_{TP4-TP5} = 0.5$  volts AC
5.  $V_{TP7-TP8} = 1.1$  volts DC
6.  $V_{TP9-TP10} = 1.1$  volts DC

Based on these measurements, what do you suspect has failed in this supply circuit? Explain your answer. Also, critique this technician's troubleshooting technique and make your own suggestions for a more efficient pattern of steps.

[file 00796](#)

Question 56

A technician is troubleshooting a power supply circuit with no DC output voltage. The output voltage is supposed to be 15 volts DC:

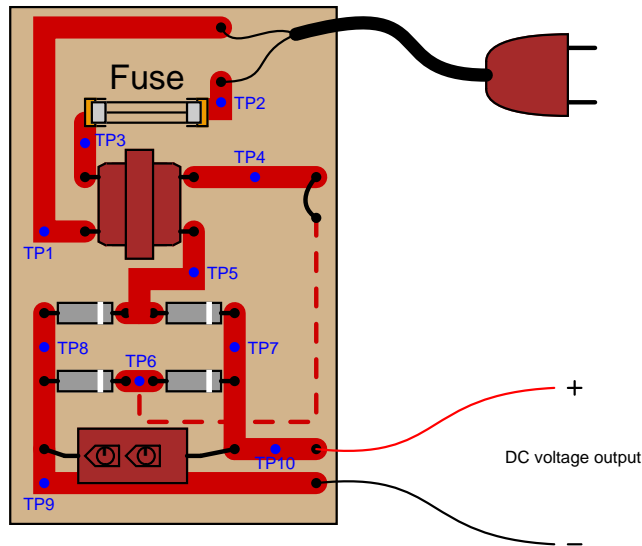

The technician begins making voltage measurements between some of the test points (TP) on the circuit board. What follows is a sequential record of his measurements:

1.  $V_{TP9-TP10} = 0$  volts DC
2.  $V_{TP1-TP2} = 117$  volts AC
3.  $V_{TP1-TP3} = 117$  volts AC
4.  $V_{TP5-TP6} = 0$  volts AC
5.  $V_{TP7-TP8} = 0.1$  volts DC
6.  $V_{TP5-TP4} = 12$  volts AC
7.  $V_{TP7-TP6} = 0$  volts DC

Based on these measurements, what do you suspect has failed in this supply circuit? Explain your answer. Also, critique this technician's troubleshooting technique and make your own suggestions for a more efficient pattern of steps.

file 00797



Question 57

AC-DC power supplies are a cause of harmonic currents in AC power systems, especially large AC-DC power supplies used in motor control circuits and other high-power controls. In this example, I show the waveforms for output voltage and input current for an unloaded AC-DC power supply with a step-down transformer, full-wave rectifier, and capacitive filter circuit (the unfiltered DC voltage waveform is shown as a dashed line for reference):

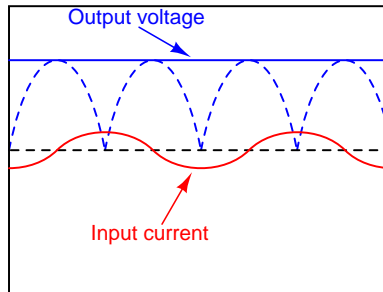

As you can see, the input current waveform lags the voltage waveform by  $90^\circ$ , because when the power supply is unloaded, the only input current is the *magnetizing current* of the transformer's primary winding.

With increased loading, the output ripple voltage becomes more pronounced. This also changes the input current waveform significantly, making it non-sinusoidal. Trace the shape of the input current waveform, given the output voltage waveform and magnetizing current waveform (dotted line) shown here:

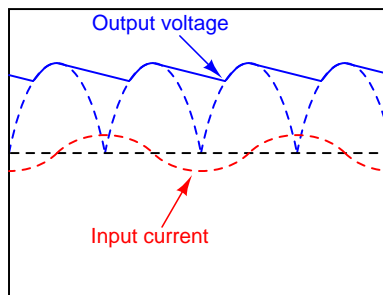

The non-filtered DC output waveform is still shown as a dotted line, for reference purposes.  
[file 00793](#)

---

Question 58

Power supplies are sometimes equipped with *EMI/RFI* filters on their inputs, to prevent high-frequency "noise" voltage created within the power supply circuit from getting back to the power source where it might interfere with other powered equipment. This is especially useful for "switching" power supply circuits, where transistors are used to switch power on and off very rapidly in the voltage transformation and regulation process:

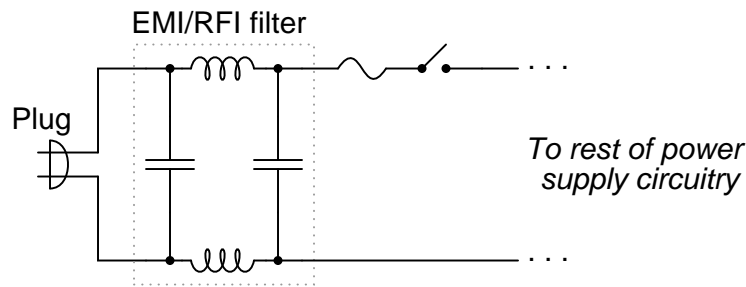

Determine what type of filter circuit this is (LP, HP, BP, or BS), and also determine the inductive and capacitive reactances of its components at 60 Hz, if the inductors are  $100 \mu\text{H}$  each and the capacitors are  $0.022 \mu\text{F}$  each.

[file 03699](#)

---

Question 59

A technician builds a simple half-wave rectifier circuit for a project, but is surprised to find that the diode keeps failing:

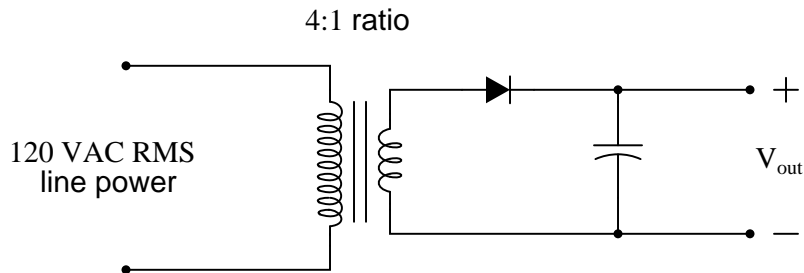

This comes as a surprise because the diode has a repetitive peak reverse voltage rating of 50 volts, which the technician knows is greater than the peak voltage output by the step-down transformer. However, the technician has overlooked something very important in this circuit design. Explain what the problem is, and how to solve it.

[file 02007](#)

---

Question 60

Complete this schematic diagram, turning it into a *split* (or *dual*) power supply, with three output terminals: +V, Ground, and -V:

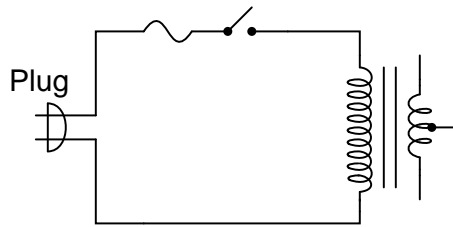

[file 02031](#)

---

Question 61

Explain what a *Schottky diode* is, and how it differs in construction and in function from a normal semiconductor PN junction diode.

[file 02068](#)

---

Question 62

Draw the schematic symbol for a *Schottky diode*, and give some examples of typical applications for it.

[file 02069](#)

---

Question 63

The characteristically colored glow from a gas-discharge electric light is the result of energy emitted by electrons in the gas atoms as they fall from high-level "excited" states back to their natural ("ground") states. As a general rule of electron behavior, they must absorb energy from an external source to leap into a higher level, and they release that energy upon returning to their original level.

Given the existence of this phenomenon, what do you suspect might be occurring inside a PN junction as it conducts an electric current?

[file 00911](#)

---

Question 64

What determines the color of an LED?

[file 01028](#)

---

Question 65

What is the typical forward voltage drop for a light-emitting diode? What is the typical forward current for an LED?

[file 01027](#)

---

Question 66

Light-emitting diodes, or *LEDs*, are rugged and highly efficient sources of light. They are far more rugged and efficient than incandescent lamps, and they also have the ability to switch on and off much faster because there is no filament inside needing to heat or cool:

Close-up view of a light-emitting diode

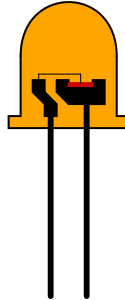

LEDs are low voltage devices, typically rated in the range of 1.5 to 2 volts DC maximum. Single diodes generally draw low currents as well, about 20 milliamps each. The problem is, how do you operate an LED from a typical electronic power source, which may output 24 volts DC or more?

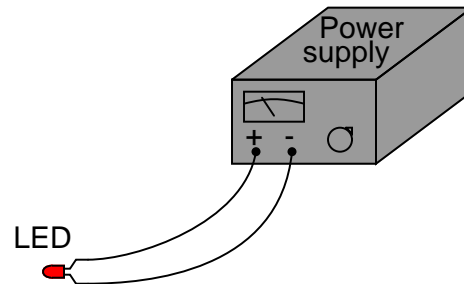

*The LED will become damaged if overpowered!*

The answer is to use a *series dropping resistor*:

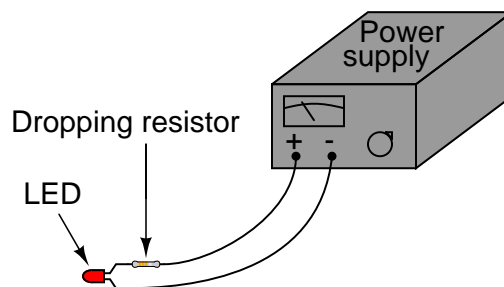

Calculate the necessary resistance value and minimum power rating of a series dropping resistor for an LED rated at 1.7 volts and 20 mA, and a power supply voltage of 24 volts.  
[file 01776](#)

---

Question 67

There is a special type of diode called a *varactor*, which is used to create a voltage-dependent capacitance. This function is often used in electronic radio tuner circuits:

*Varactor diode symbol*

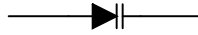

The voltage-dependent capacitance of this diode is given by the following equation:

$$C_j = \frac{C_o}{\sqrt{2V + 1}}$$

Where,

$C_j$  = Junction capacitance

$C_o$  = Junction capacitance with no applied voltage

$V$  = Applied reverse junction voltage

Based on this equation, would you say that capacitance is *directly* or *inversely* related to the applied reverse-bias voltage of a varactor diode? Based on what you know of diode theory, explain why this makes sense.

[file 01386](#)

---

Question 68

Shown here is the characteristic curve of a diode:

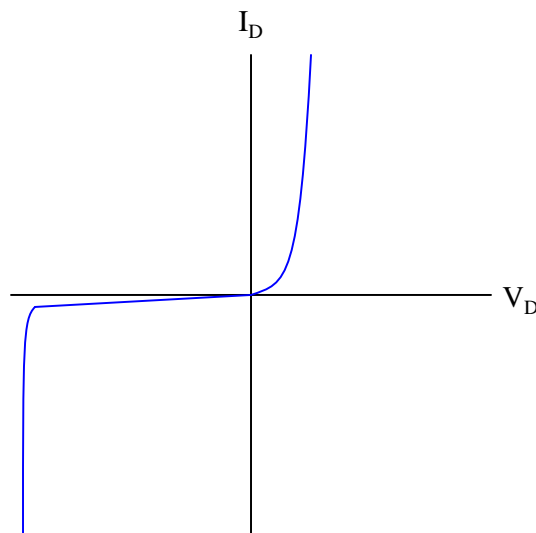

Identify which area of this curve represents normal forward-biased operation, and which represents reverse-biased operation. Also, explain the significance of the near-vertical portion of the curve in the lower-left quadrant of the graph.

[file 02019](#)

---

Question 69

How does the behavior of a *zener diode* differ substantially from that of a normal (rectifying) diode?

[file 01052](#)

---

Question 70

Suppose you had the boring job of manually maintaining the output voltage of a DC generator constant. Your one and only control over voltage is the setting of a rheostat:

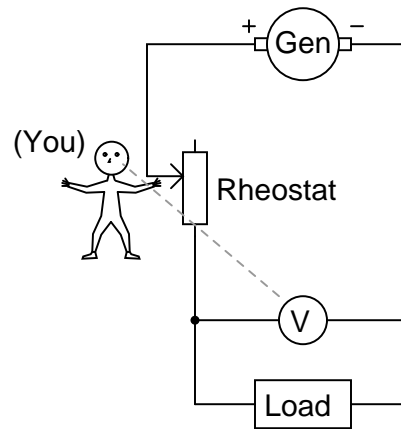

What would you have to do to maintain the load voltage constant if the load resistance changed so as to draw more current? Being that your only control over load voltage is the adjustment of a variable resistance in series with the generator, what does this imply about the generator's output voltage (directly across the generator terminals), compared to the target load voltage?

[file 00888](#)

---

Question 71

Suppose you had the boring job of manually maintaining the output voltage of a DC generator constant. Your one and only control over voltage is the setting of a rheostat:

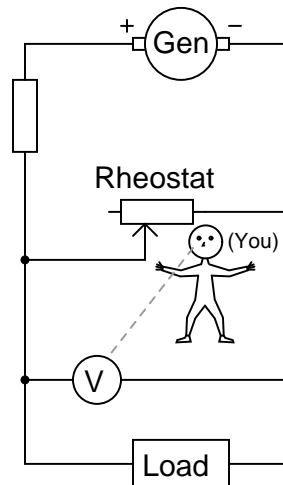

What would you have to do to maintain the load voltage constant if the load resistance changed so as to draw more current? Being that your only control over load voltage is the adjustment of a variable resistance in parallel with the load, what does this imply about the generator's output voltage (directly across the generator terminals), compared to the target load voltage?

[file 00889](#)

---

Question 72

Describe how a zener diode is able to maintain regulated (nearly constant) voltage across the load, despite changes in load current:

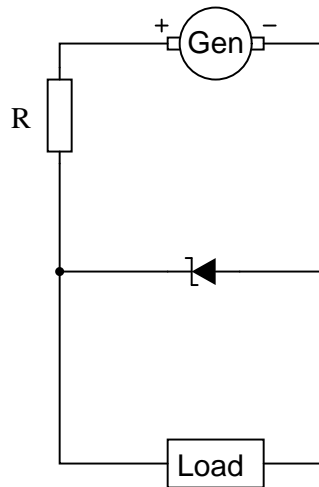

file 00890

---

Question 73

Calculate the current through the zener diode for the given values of load resistance in this circuit:

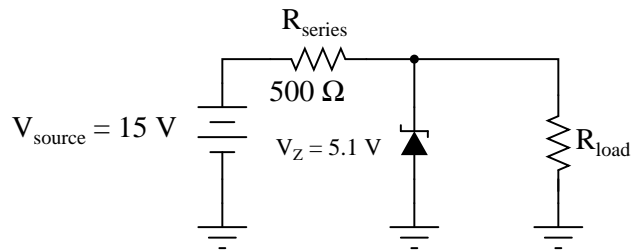

- $R_{load} = 1 \text{ k}\Omega$  ;  $I_{zener} =$
- $R_{load} = 910 \text{ }\Omega$  ;  $I_{zener} =$
- $R_{load} = 680 \text{ }\Omega$  ;  $I_{zener} =$
- $R_{load} = 470 \text{ }\Omega$  ;  $I_{zener} =$
- $R_{load} = 330 \text{ }\Omega$  ;  $I_{zener} =$

Do you see any relationship between load current and zener diode current? If so, explain what that relationship is.

file 02017

---

Question 74

Calculate the current through the zener diode for the given values of input (source) voltage in this circuit:

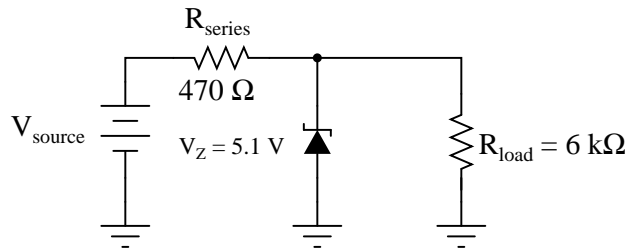

- $V_{source} = 25 \text{ V}$  ;  $I_{zener} =$
- $V_{source} = 20 \text{ V}$  ;  $I_{zener} =$
- $V_{source} = 15 \text{ V}$  ;  $I_{zener} =$
- $V_{source} = 10 \text{ V}$  ;  $I_{zener} =$
- $V_{source} = 5 \text{ V}$  ;  $I_{zener} =$

Do you see any relationship between source voltage and zener diode current? If so, explain what that relationship is.

[file 03841](#)

---

Question 75

Zener diodes are simple and useful devices for building voltage regulator circuits, but are times when you may have to improvise in the absence of the proper zener diode. Explain how normal diodes might be used as crude substitutes for a zener diode in the following circuit:

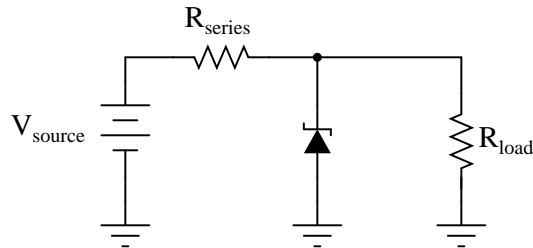

[file 02018](#)



---

Question 76

At what load resistance value will this voltage regulator circuit begin to lose its ability to regulate voltage? Also, determine whether the voltage regulation is lost for load resistance values greater than this threshold value, or less than this threshold value.

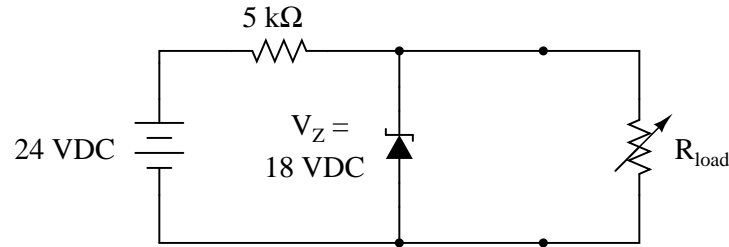

[file 01066](#)

---

Question 77

Not all "zener" diodes break down in the exact same manner. Some operate on the principle of *zener breakdown*, while others operate on the principle of *avalanche breakdown*. How do the temperature coefficients of these two zener diode types compare, and how are you able to discern whether a zener diode uses one principle or the other just from its breakdown voltage rating?

Correspondingly, is there a way we could determine the type of breakdown action from experimental measurements on a zener diode? Explain how such an experiment might be set up.

[file 01053](#)

---

Question 78

Precision voltage reference regulators are often constructed of two zener diodes connected in series like this:



Explain why *two* zener diodes provide greater stability than a single zener diode would, and also draw a circuit showing a voltage source, so this component functions as a complete voltage reference.

[file 01062](#)

---

Question 79

What type of diode is always packaged in a clear glass or plastic body (as opposed to an opaque plastic body)? Explain how the appearance of the component is helpful in determining its identity.

[file 03444](#)

---

Question 80

$\int f(x) dx$  *Calculus alert!*

How is the parameter of *zener impedance* defined for a zener diode? Should an ideal zener diode have a zener impedance figure equal to zero, or infinite? Why?

[file 01065](#)

---

Question 81

Show which directions these free-floating ions would move, if exposed to an electric field of the polarity shown:

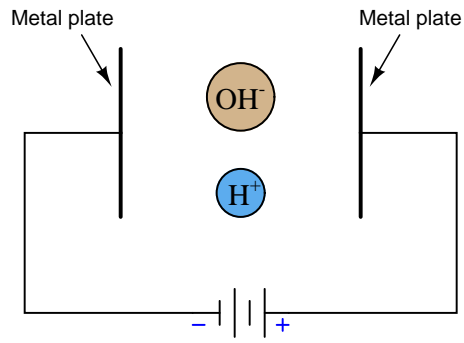

Note: the "H<sup>+</sup>" ion is a positively charged hydrogen atom, while the "OH<sup>-</sup>" ion is a negatively charged hydroxyl ion.

[file 04083](#)

---

Question 82

In this electrical circuit, trace the direction of current through the wires:

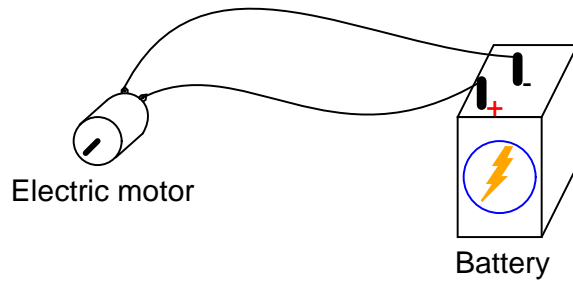

[file 00176](#)

---

Question 83

Label the directions of both electron flow and conventional flow in this simple circuit:

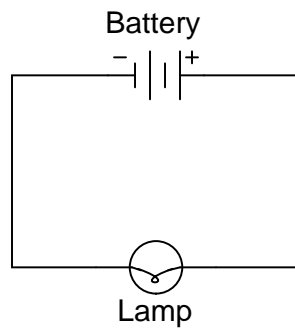

[file 04078](#)

---

Question 84

In metallic conductors, the dominant carriers of electric charge are *free electrons*, which of course are negatively charged. Are there any examples of electric conduction where electric charge is carried by positively-charged particles?

[file 04076](#)

---

Question 85

Explain, in your own words, how we came to have two completely opposite notations for labeling the direction of electric current. What historical events led to this confusion, and why does it still exist today?

[file 04077](#)

---

Question 86

When you see an electronic device symbol such as any one of these, which direction do the symbols' intrinsic arrows represent, electron or conventional flow?

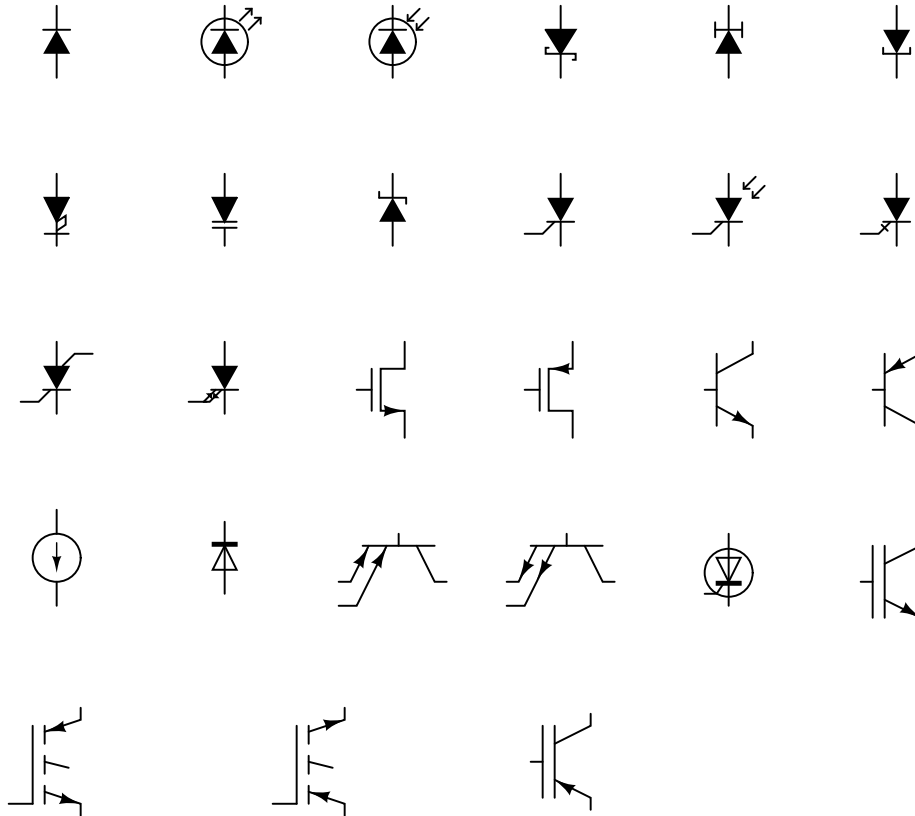

[file 04080](#)

---

Question 87

Two people are debating electron flow versus conventional flow. One of them says that the you will get different results predicting polarity of voltage drops in a resistive circuit depending on which convention you use. The other person says the convention for labeling current does not matter at all, and that the correct polarities will be predicted either way.

Which of these two people is correct? Explain why, and give an example to prove your point.

[file 04082](#)

---

Question 88

Suppose a person is more familiar with conventional flow notation than electron flow notation. If this person find themselves in a situation where they *must* draw the direction of current according to electron flow notation, what advice would you give them for making the transition.

[file 04079](#)

---

Question 89

A *Cathode Ray Tube*, or *CRT*, is the heart of an analog oscilloscope. It functions by aiming a focused beam of electrons at a phosphorescent screen, causing light at the point of impact:

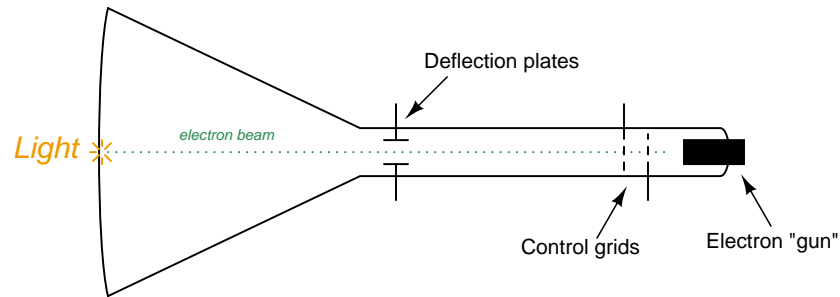

What style of current notation (electron or conventional) would best suit a description for the operation of a CRT?

[file 04081](#)

Question 90

In the following graphic, you will see the directions of currents labeled with arrows for each semiconductor component. Some of these arrows are pointing in the direction of conventional flow, while others are pointing in the direction of electron flow. Determine which convention is being used to label currents for each component (note: I have only used one convention for each component – I have not mixed conventional and electron flow while labeling multiple currents on the same component!).

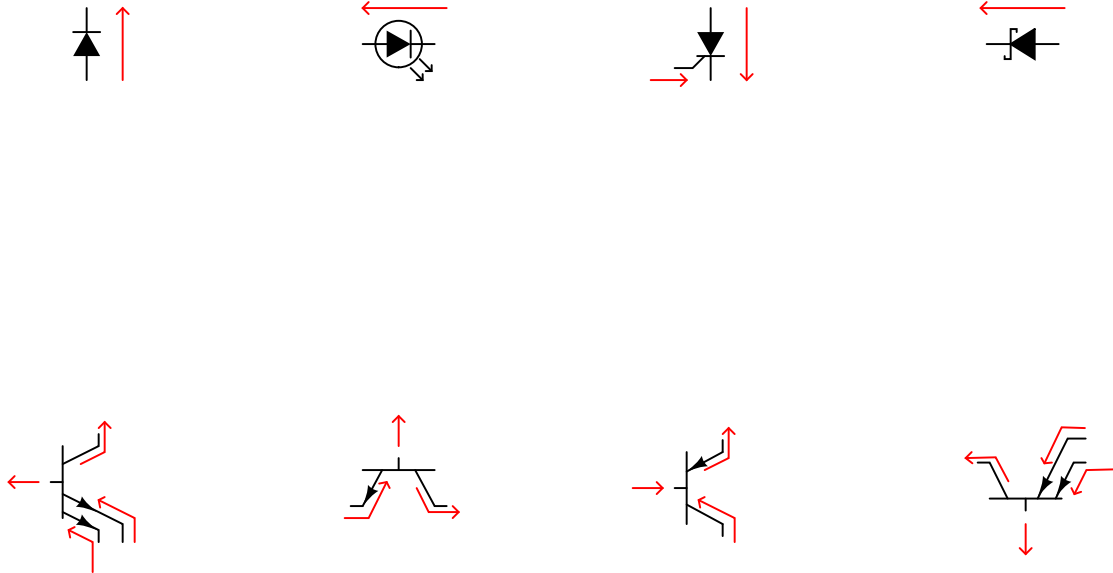

file 04084

Competency: <b>Rectifying diode behavior</b>		Version:	
<b>Schematic</b>			
<p><i>Forward-biased</i></p>		<p><i>Reverse-biased</i></p>	
<b>Given conditions</b>			
$V_{\text{supply}} =$ (see multiple values given below) $R_1 =$			
<b>Parameters</b> <i>Forward-biased</i>			
$V_{\text{supply}} =$	Given	$V_{R1}$	Predicted
	<input style="width: 100px; height: 20px;" type="text"/>	$V_{D1}$	Measured
			<input style="width: 100px; height: 20px;" type="text"/>
			<input style="width: 100px; height: 20px;" type="text"/>
$V_{\text{supply}} =$	Given	$V_{R1}$	Predicted
	<input style="width: 100px; height: 20px;" type="text"/>	$V_{D1}$	Measured
			<input style="width: 100px; height: 20px;" type="text"/>
			<input style="width: 100px; height: 20px;" type="text"/>
<b>Parameters</b> <i>Reverse-biased</i>			
$V_{\text{supply}} =$	Given	$V_{R1}$	Predicted
	<input style="width: 100px; height: 20px;" type="text"/>	$V_{D1}$	Measured
			<input style="width: 100px; height: 20px;" type="text"/>
			<input style="width: 100px; height: 20px;" type="text"/>
$V_{\text{supply}} =$	Given	$V_{R1}$	Predicted
	<input style="width: 100px; height: 20px;" type="text"/>	$V_{D1}$	Measured
			<input style="width: 100px; height: 20px;" type="text"/>
			<input style="width: 100px; height: 20px;" type="text"/>

Competency: <b>Full-wave center-tap rectifier</b>	Version:																
<b>Schematic</b>																	
<b>Given conditions</b>																	
$V_{\text{secondary}} =$ (VAC RMS)	$R_{\text{load}} =$																
<b>Parameters</b>																	
<table border="1" style="margin-left: auto; margin-right: auto;"> <thead> <tr> <th style="padding: 5px;"></th> <th style="padding: 5px;">Predicted</th> <th style="padding: 5px;">Measured</th> <th style="padding: 5px;"></th> </tr> </thead> <tbody> <tr> <td style="padding: 5px;"><math>V_{\text{load(DC)}}</math></td> <td style="width: 60px; height: 25px;"></td> <td style="width: 60px; height: 25px;"></td> <td style="padding: 5px;">(Approximate only)</td> </tr> <tr> <td style="padding: 5px;"><math>V_{\text{ripple}}</math></td> <td style="width: 60px; height: 25px;"></td> <td style="width: 60px; height: 25px;"></td> <td></td> </tr> <tr> <td style="padding: 5px;"><math>f_{\text{ripple}}</math></td> <td style="width: 60px; height: 25px;"></td> <td style="width: 60px; height: 25px;"></td> <td></td> </tr> </tbody> </table>		Predicted	Measured		$V_{\text{load(DC)}}$			(Approximate only)	$V_{\text{ripple}}$				$f_{\text{ripple}}$				
	Predicted	Measured															
$V_{\text{load(DC)}}$			(Approximate only)														
$V_{\text{ripple}}$																	
$f_{\text{ripple}}$																	
<b>Fault analysis</b>																	
<p>Suppose component <input style="width: 40px; height: 20px;" type="text"/> fails <input type="checkbox"/> open <input type="checkbox"/> other _____</p> <p><input type="checkbox"/> shorted</p> <p><i>What will happen in the circuit?</i></p>																	

file 01942

Competency: <b>Full-wave bridge rectifier</b>	Version:																
<b>Schematic</b>																	
<b>Given conditions</b>																	
$V_{\text{secondary}} =$ (VAC RMS)	$R_{\text{load}} =$																
<b>Parameters</b>																	
<table border="1" style="margin-left: auto; margin-right: auto;"> <thead> <tr> <th style="padding: 5px;"></th> <th style="padding: 5px;">Predicted</th> <th style="padding: 5px;">Measured</th> <th style="padding: 5px;"></th> </tr> </thead> <tbody> <tr> <td style="padding: 5px;"><math>V_{\text{load(DC)}}</math></td> <td style="width: 60px; height: 25px;"></td> <td style="width: 60px; height: 25px;"></td> <td style="padding: 5px;">(Approximate only)</td> </tr> <tr> <td style="padding: 5px;"><math>V_{\text{ripple}}</math></td> <td style="width: 60px; height: 25px;"></td> <td style="width: 60px; height: 25px;"></td> <td></td> </tr> <tr> <td style="padding: 5px;"><math>f_{\text{ripple}}</math></td> <td style="width: 60px; height: 25px;"></td> <td style="width: 60px; height: 25px;"></td> <td></td> </tr> </tbody> </table>		Predicted	Measured		$V_{\text{load(DC)}}$			(Approximate only)	$V_{\text{ripple}}$				$f_{\text{ripple}}$				
	Predicted	Measured															
$V_{\text{load(DC)}}$			(Approximate only)														
$V_{\text{ripple}}$																	
$f_{\text{ripple}}$																	
<b>Fault analysis</b>																	
<p>Suppose component <span style="border: 1px solid black; display: inline-block; width: 30px; height: 15px; vertical-align: middle;"></span> fails <input type="checkbox"/> open <input type="checkbox"/> other _____</p> <p><input type="checkbox"/> shorted</p> <p><i>What will happen in the circuit?</i></p>																	

file 01943



<b>Competency: Zener diode voltage regulator</b>		Version:
<b>Schematic</b>		
<b>Given conditions</b>		
$V_{supply} =$	$V_{zener} =$	$R_{series} =$ $R_{load} =$
<b>Parameters</b>		
	Predicted	Measured
$V_{load}$ (nominal)	<input style="width: 100px; height: 20px;" type="text"/>	<input style="width: 100px; height: 20px;" type="text"/>
$V_{supply}$ (max)	<input style="width: 100px; height: 20px;" type="text"/>	<input style="width: 100px; height: 20px; border: 1px solid black; background: repeating-linear-gradient(45deg, transparent, transparent 2px, black 2px, black 4px);" type="text"/>
$V_{supply}$ (min)	<input style="width: 100px; height: 20px;" type="text"/>	<input style="width: 100px; height: 20px;" type="text"/>
<b>Fault analysis</b>		
Suppose component <input style="width: 50px; height: 20px;" type="text"/> fails <input type="checkbox"/> open <input type="checkbox"/> other _____ <input type="checkbox"/> shorted What will happen in the circuit?		

The  $V_{supply}$  (min) parameter is the minimum voltage setting that  $V_{supply}$  may be adjusted to with the regulator circuit maintaining constant load voltage at  $R_{load}$ .  $V_{supply}$  (max) is the maximum voltage that  $V_{supply}$  may be adjusted to without exceeding the zener diode's power rating.  $V_{load}$  (nominal) is simply the regulated voltage output of the circuit under normal conditions.

file 01623

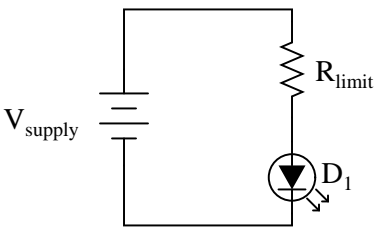
Competency: <b>LED current limiting</b>	Version:																						
<b>Schematic</b>																							
																							
<b>Given conditions</b>																							
$V_{\text{supply}} =$	$V_{\text{forward (LED)}} =$	$I_{\text{forward(LED)}} =$																					
<b>Parameters</b>																							
<table style="width: 100%; border-collapse: collapse;"> <tr> <td style="width: 30%;"></td> <td style="width: 35%; text-align: center;">Given</td> <td style="width: 15%;"></td> <td style="width: 15%; text-align: center;">Predicted</td> <td style="width: 15%; text-align: center;">Measured</td> </tr> <tr> <td style="vertical-align: top;"><math>V_{\text{supply}} =</math></td> <td style="text-align: center;"><input style="width: 100%;" type="text"/></td> <td style="vertical-align: top;"><math>V_{R_{\text{limit}}}</math></td> <td style="text-align: center;"><input style="width: 100%;" type="text"/></td> <td style="text-align: center;"><input style="width: 100%;" type="text"/></td> </tr> <tr> <td></td> <td></td> <td style="vertical-align: top;"><math>V_{D1}</math></td> <td style="text-align: center;"><input style="width: 100%;" type="text"/></td> <td style="text-align: center;"><input style="width: 100%;" type="text"/></td> </tr> <tr> <td></td> <td></td> <td style="vertical-align: top;"><math>I_{D1}</math></td> <td style="text-align: center;"><input style="width: 100%;" type="text"/></td> <td style="text-align: center;"><input style="width: 100%;" type="text"/></td> </tr> </table>		Given		Predicted	Measured	$V_{\text{supply}} =$	<input style="width: 100%;" type="text"/>	$V_{R_{\text{limit}}}$	<input style="width: 100%;" type="text"/>	<input style="width: 100%;" type="text"/>			$V_{D1}$	<input style="width: 100%;" type="text"/>	<input style="width: 100%;" type="text"/>			$I_{D1}$	<input style="width: 100%;" type="text"/>	<input style="width: 100%;" type="text"/>			
	Given		Predicted	Measured																			
$V_{\text{supply}} =$	<input style="width: 100%;" type="text"/>	$V_{R_{\text{limit}}}$	<input style="width: 100%;" type="text"/>	<input style="width: 100%;" type="text"/>																			
		$V_{D1}$	<input style="width: 100%;" type="text"/>	<input style="width: 100%;" type="text"/>																			
		$I_{D1}$	<input style="width: 100%;" type="text"/>	<input style="width: 100%;" type="text"/>																			
<b>Analysis</b>																							
<p>Show how you calculated the appropriate value for <math>R_{\text{limit}}</math></p>  <p>Draw the directions of both electron and conventional current</p>																							
<b>Fault analysis</b>																							
<p>Suppose component <input style="width: 50px;" type="text"/> fails <input type="checkbox"/> open <input type="checkbox"/> other _____</p> <p><input type="checkbox"/> shorted</p> <p><i>What will happen in the circuit?</i></p>																							

file 04075

---

Question 96

NAME: \_\_\_\_\_

**Project Grading Criteria**

PROJECT: \_\_\_\_\_

You will receive the highest score for which *all* criteria are met.

100 % (*Must meet or exceed all criteria listed*)

- A. Impeccable craftsmanship, comparable to that of a professional assembly
- B. No spelling or grammatical errors anywhere in *any* document, upon first submission to instructor

95 % (*Must meet or exceed these criteria in addition to all criteria for 90% and below*)

- A. Technical explanation sufficiently detailed to teach from, inclusive of every component (supersedes 75.B)
- B. Itemized parts list complete with part numbers, manufacturers, and (equivalent) prices for *all* components, including recycled components and parts kit components (supersedes 90.A)

90 % (*Must meet or exceed these criteria in addition to all criteria for 85% and below*)

- A. Itemized parts list complete with prices of components purchased for the project, plus total price
- B. No spelling or grammatical errors anywhere in *any* document upon final submission

85 % (*Must meet or exceed these criteria in addition to all criteria for 80% and below*)

- A. “User’s guide” to project function (in addition to 75.B)
- B. Troubleshooting log describing all obstacles overcome during development and construction

80 % (*Must meet or exceed these criteria in addition to all criteria for 75% and below*)

- A. All controls (switches, knobs, etc.) clearly and neatly labeled
- B. All documentation created on computer, not hand-written (including the schematic diagram)

75 % (*Must meet or exceed these criteria in addition to all criteria for 70% and below*)

- A. Stranded wire used wherever wires are subject to vibration or bending
- B. Basic technical explanation of all major circuit sections
- C. Deadline met for working prototype of circuit (Date/Time = \_\_\_\_\_ / \_\_\_\_\_ )

70 % (*Must meet or exceed these criteria in addition to all criteria for 65%*)

- A. All wire connections sound (solder joints, wire-wrap, terminal strips, and lugs are all connected properly)
- B. No use of glue where a fastener would be more appropriate
- C. Deadline met for submission of fully-functional project (Date/Time = \_\_\_\_\_ / \_\_\_\_\_ ) – supersedes 75.C if final project submitted by that (earlier) deadline

65 % (*Must meet or exceed these criteria in addition to all criteria for 60%*)

- A. Project fully functional
- B. All components securely fastened so nothing is “loose” inside the enclosure
- C. Schematic diagram of circuit

60 % (*Must meet or exceed these criteria in addition to being safe and legal*)

- A. Project minimally functional, with all components located inside an enclosure (if applicable)
- B. Passes final safety inspection (proper case grounding, line power fusing, power cords strain-relieved)

0 % (*If any of the following conditions are true*)

- A. Fails final safety inspection (improper grounding, fusing, and/or power cord strain relieving)
- B. Intended project function poses a safety hazard
- C. Project function violates any law, ordinance, or school policy

file 03173

---

Question 97

Predict how all test point voltages (measured between each test point and ground) in this circuit will be affected as a result of the following faults. Consider each fault independently (i.e. one at a time, no multiple faults):

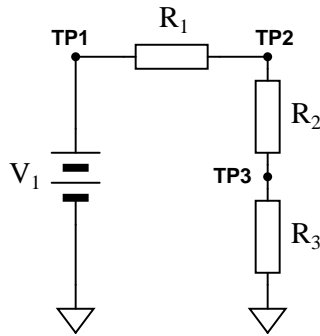

- Resistor  $R_1$  fails open:
- Resistor  $R_2$  fails open:
- Resistor  $R_3$  fails open:
- Solder bridge (short) past resistor  $R_2$ :

For each of these conditions, explain *why* the resulting effects will occur.

[file 03709](#)

---

Question 98

Predict how all component voltages and currents in this circuit will be affected as a result of the following faults. Consider each fault independently (i.e. one at a time, no multiple faults):

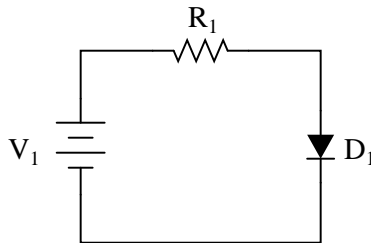

- Diode  $D_1$  fails open:
- Diode  $D_1$  fails shorted:
- Resistor  $R_1$  fails open:
- Solder bridge (short) past resistor  $R_1$ :

For each of these conditions, explain *why* the resulting effects will occur.

[file 03700](#)

---

Question 99

Predict how all component voltages and currents in this circuit will be affected as a result of the following faults. Consider each fault independently (i.e. one at a time, no multiple faults):

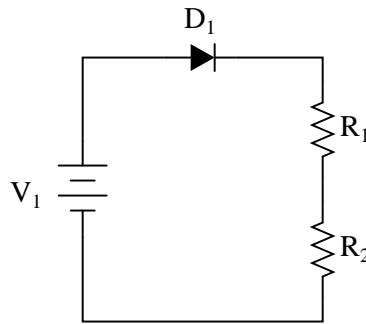

- Diode  $D_1$  fails open:
- Diode  $D_1$  fails shorted:
- Resistor  $R_1$  fails open:
- Resistor  $R_2$  fails open:

For each of these conditions, explain *why* the resulting effects will occur.

[file 03701](#)

---

Question 100

Predict how all component voltages and currents in this circuit will be affected as a result of the following faults. Consider each fault independently (i.e. one at a time, no multiple faults):

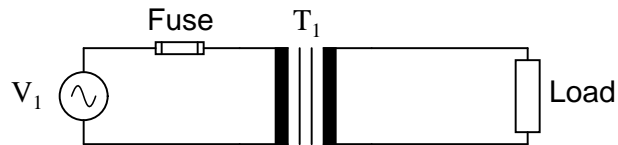

- Transformer  $T_1$  primary winding fails open:
- Transformer  $T_1$  primary winding fails shorted:
- Transformer  $T_1$  secondary winding fails open:
- Load fails shorted:

For each of these conditions, explain *why* the resulting effects will occur.

[file 03707](#)

---

Question 101

Predict how all component voltages and currents in this circuit will be affected as a result of the following faults. Consider each fault independently (i.e. one at a time, no multiple faults):

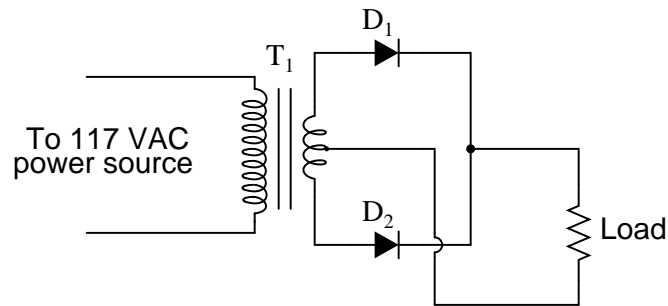

- Diode  $D_1$  fails open:
- Diode  $D_2$  fails open:
- Load resistor fails open:
- Transformer  $T_1$  primary winding fails open:

For each of these conditions, explain *why* the resulting effects will occur.

[file 03702](#)

---

Question 102

Predict how all component voltages and currents in this circuit will be affected as a result of the following faults. Consider each fault independently (i.e. one at a time, no multiple faults):

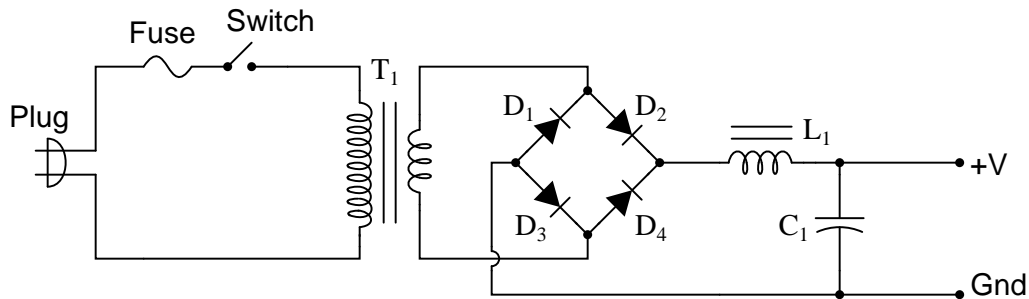

- Any one diode fails open:
- Transformer secondary winding fails open:
- Inductor  $L_1$  fails open:
- Capacitor  $C_1$  fails shorted:

For each of these conditions, explain *why* the resulting effects will occur.

[file 03703](#)

---

Question 103

Suppose this power supply circuit was working fine for several years, then one day failed to output any DC voltage at all:

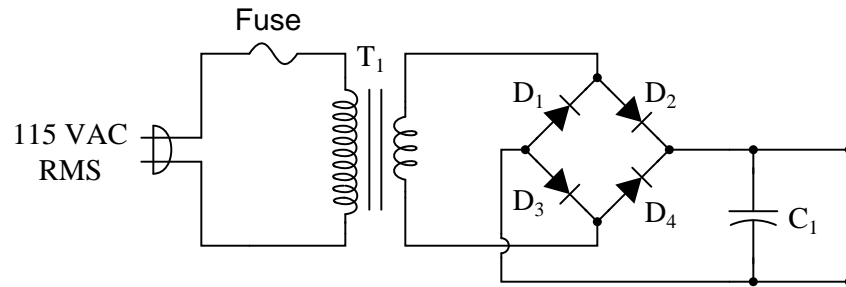

When you open the case of this power supply, you immediately notice the strong odor of burnt components. From this information, determine some likely component faults and explain your reasoning.

[file 03708](#)

---

Question 104

Predict how all component voltages and currents in this circuit will be affected as a result of the following faults. Consider each fault independently (i.e. one at a time, no multiple faults):

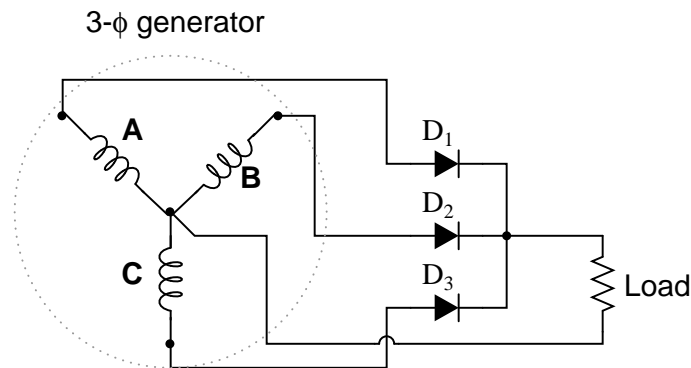

- Diode  $D_1$  fails open:
- Generator winding  $C$  fails open:
- Center connection joining generator windings fails open:

For each of these conditions, explain *why* the resulting effects will occur.

[file 03706](#)

---

Question 105

Predict how all component voltages and currents in this circuit will be affected as a result of the following faults. Consider each fault independently (i.e. one at a time, no multiple faults):

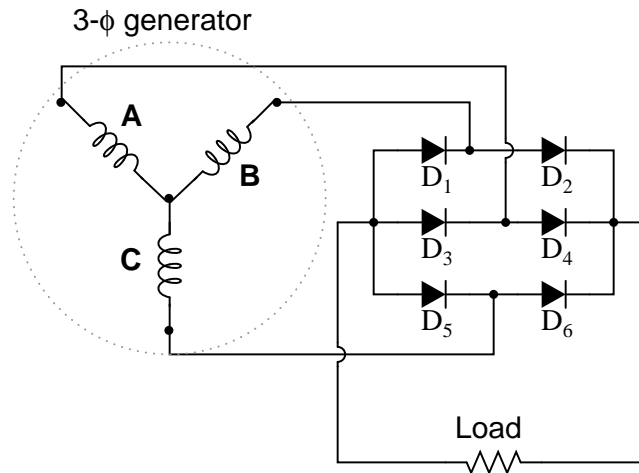

- Diode  $D_3$  fails open:
- Generator winding  $C$  fails open:
- Center connection joining generator windings fails open:

For each of these conditions, explain *why* the resulting effects will occur.

[file 03705](#)

---

Question 106

Predict how all component voltages and currents in this circuit will be affected as a result of the following faults. Consider each fault independently (i.e. one at a time, no multiple faults):

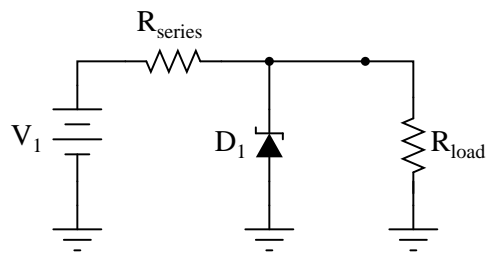

- Zener diode fails shorted:
- Zener diode fails open:
- Series resistor fails open:
- Series resistor fails shorted:

For each of these conditions, explain *why* the resulting effects will occur.

[file 03704](#)



---

Question 107

How is it possible to assign a fixed value of voltage or current (such as "120 volts") to an AC electrical quantity that is constantly changing, crossing 0 volts, and reversing polarity?

[file 00051](#)

---

Question 108

Suppose a DC power source with a voltage of 50 volts is connected to a 10  $\Omega$  load. How much power will this load dissipate?

Now suppose the same 10  $\Omega$  load is connected to a sinusoidal AC power source with a *peak* voltage of 50 volts. Will the load dissipate the same amount of power, more power, or less power? Explain your answer.

[file 00401](#)

---

Question 109

Suppose that a variable-voltage AC source is adjusted until it dissipates the exact same amount of power in a standard load resistance as a DC voltage source with an output of 120 volts:

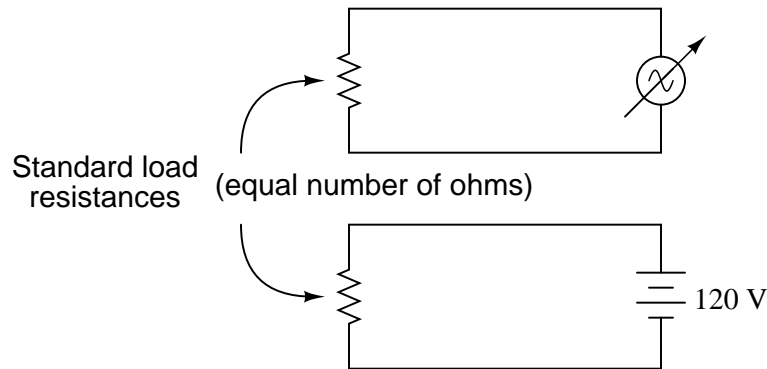

In this condition of equal power dissipation, how much voltage is the AC power supply outputting? Be as specific as you can in your answer.

[file 00402](#)

---

Question 110

Determine the RMS amplitude of this sinusoidal waveform, as displayed by an oscilloscope with a vertical sensitivity of 0.2 volts per division:

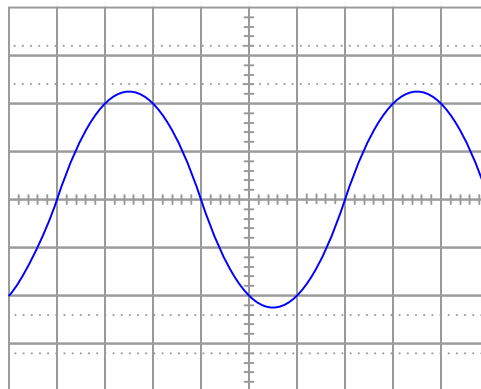

[file 01818](#)

---

Question 111

Assuming the vertical sensitivity control is set to 0.5 volts per division, and the timebase control is set to 2.5 ms per division, calculate the amplitude of this sine wave (in volts peak, volts peak-to-peak, and volts RMS) as well as its frequency.

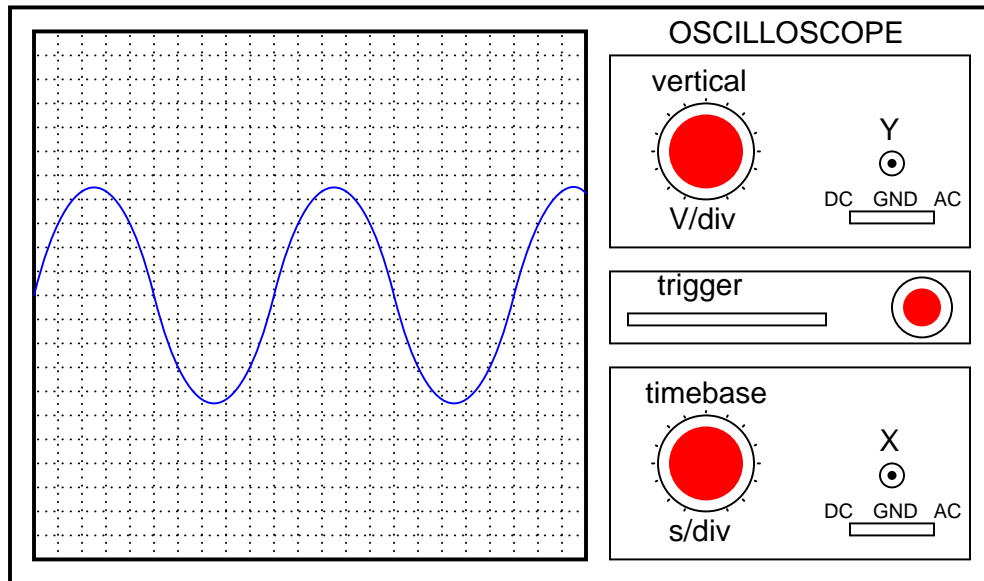

[file 00540](#)

---

Question 112

Suppose 1200 turns of copper wire are wrapped around one portion of an iron hoop, and 3000 turns of wire are wrapped around another portion of that same hoop. If the 1200-turn coil is energized with 15 volts AC (RMS), how much voltage will appear between the ends of the 3000-turn coil?

[file 00246](#)

---

Question 113

Calculate the voltage output by the secondary winding of a transformer if the primary voltage is 35 volts, the secondary winding has 4500 turns, and the primary winding has 355 turns.

$$V_{secondary} =$$

[file 02206](#)

---

Question 114

Calculate the voltage output by the secondary winding of a transformer if the primary voltage is 230 volts, the secondary winding has 290 turns, and the primary winding has 1120 turns.

$$V_{secondary} =$$

[file 02207](#)

---

Question 115

Calculate the load current and load voltage in this transformer circuit:

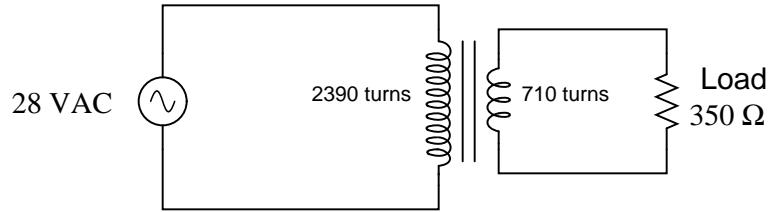

$I_{load} =$

$V_{load} =$

[file 02210](#)

---

Question 116

Calculate the source current and load current in this transformer circuit:

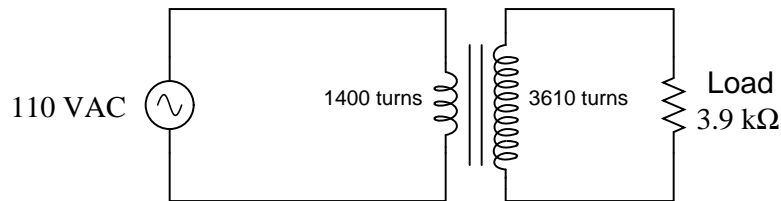

$I_{source} =$

$I_{load} =$

[file 02212](#)

---

Question 117

Describe the difference between an *intrinsic* and an *extrinsic* semiconducting substance.

[file 02295](#)

---

Question 118

What effect does doping concentration have on the electrical conductivity of an extrinsic semiconductor?

[file 00908](#)

---

Question 119

What must be done to an intrinsic semiconductor to turn it into an "N-type" semiconductor?

[file 02297](#)

---

Question 120

What must be done to an intrinsic semiconductor to turn it into a "P-type" semiconductor?

[file 02298](#)

---

Question 121

What effect does temperature have on the electrical conductivity of a semiconducting material? How does this compare with the effect of temperature on the electrical conductivity of a typical metal?

[file 00905](#)

---

Draw the approximate locations of the Fermi levels in these three energy level diagrams:

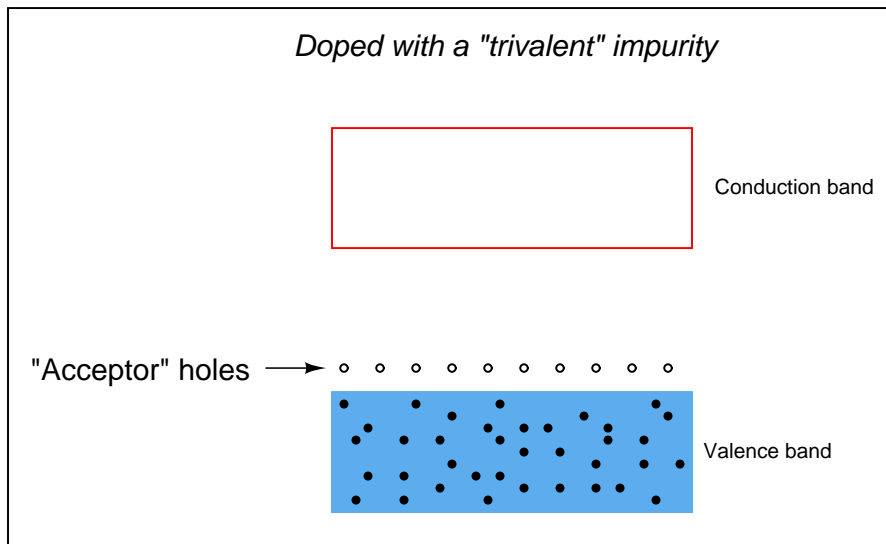
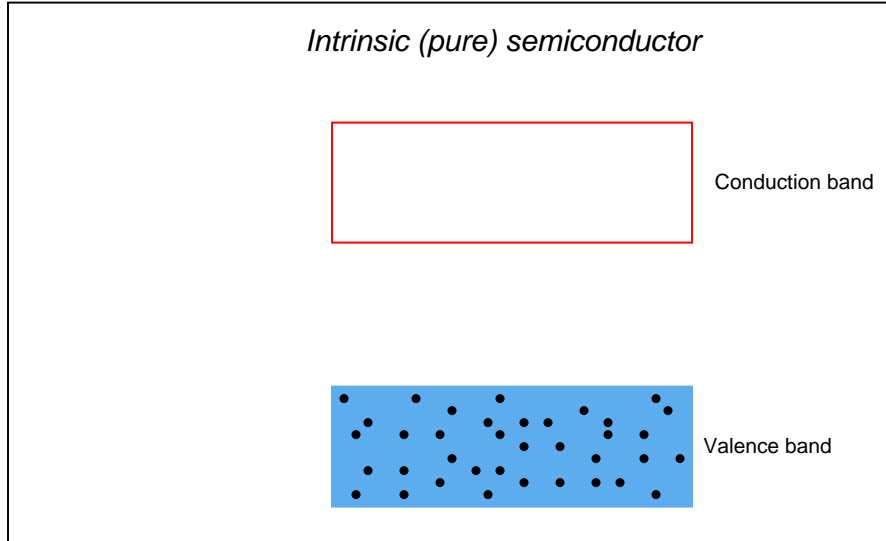

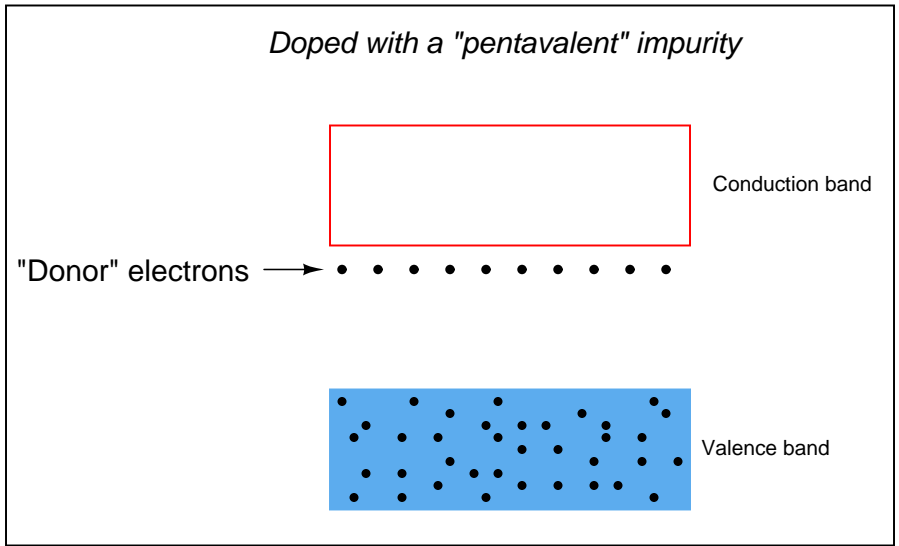

file 02004

Question 123

A fascinating experiment carried out by J. R. Hayes and W. Shockley in the early 1950's involved a bar of N-doped germanium with two metal point contacts labeled "E" and "C," for "Emitter" and "Collector," respectively:

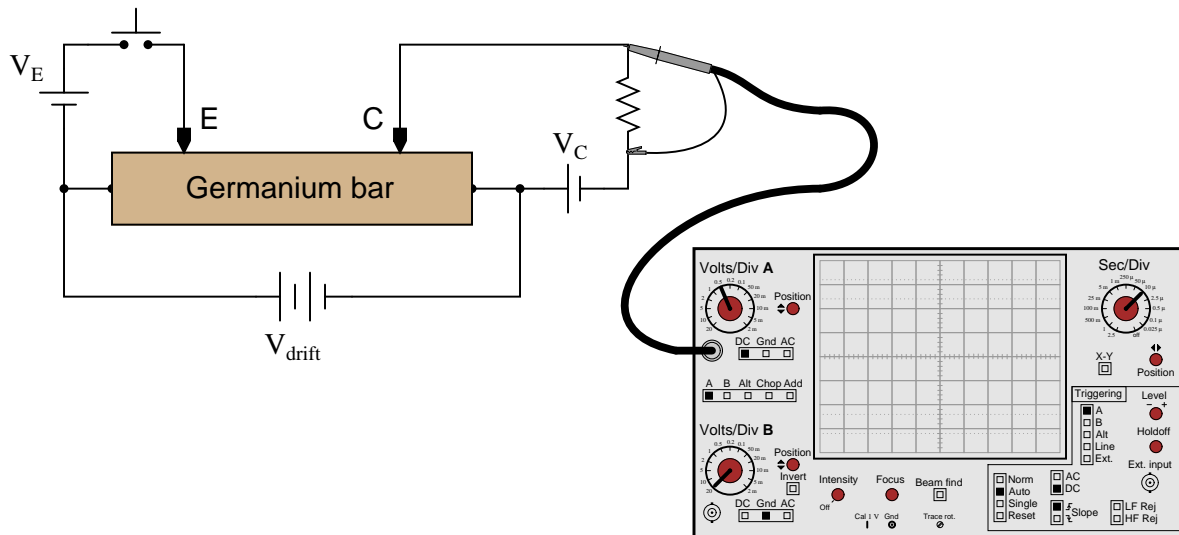

Upon actuating the switch, two distinct pulses were noted on the oscilloscope display:

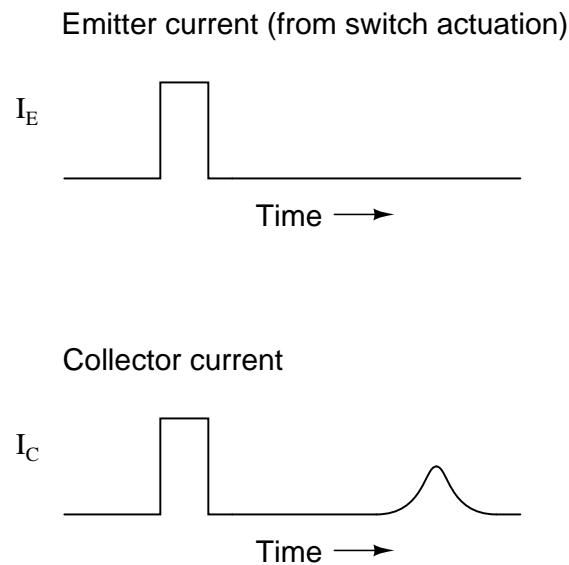

With less drift voltage ( $V_{drift}$ ) applied across the length of the bar, the second pulse was seen to be further delayed and more diffused:

Emitter current (from switch actuation)

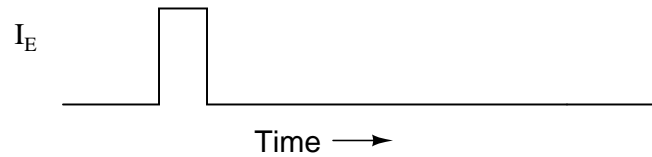

Collector current



The instantaneous effect of the first pulse (precisely timed with the closure of the switch) is not the most interesting facet of this experiment. Rather, the second (delayed) pulse is. Explain what caused this second pulse, and why its shape depended on  $V_{drift}$ .

[file 02044](#)

---

Question 124

When "P" and "N" type semiconductor pieces are brought into close contact, free electrons from the "N" piece will rush over to fill holes in the "P" piece, creating a zone on both sides of the contact region devoid of charge carriers. What is this zone called, and what are its electrical characteristics?

[file 00715](#)

---

Question 125

Is this diode *forward-biased* or *reverse biased*?

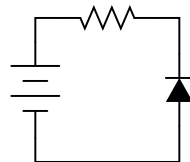

[file 02299](#)

---

Question 126

Insert a diode into this circuit schematic in the correct direction to make it *forward-biased* by the battery voltage:

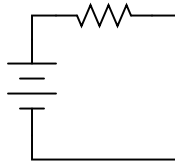

[file 02300](#)

---

Question 127

Shockley's diode equation in standard form is quite lengthy, but it may be considerably simplified for conditions of room temperature. Note that if the temperature ( $T$ ) is assumed to be room temperature ( $25^\circ$  C), there are three constants in the equation that are the same for all PN junctions:  $T$ ,  $k$ , and  $q$ .

$$I_D = I_S(e^{\frac{qV_D}{NkT}} - 1)$$

The quantity  $\frac{kT}{q}$  is known as the *thermal voltage* of the junction. Calculate the value of this thermal voltage, given a room temperature of  $25^\circ$  C. Then, substitute this quantity into the original "diode formula" so as to simplify its appearance.

[file 00713](#)



---

Question 128

A student sets up a circuit that looks like this, to gather data for characterizing a diode:

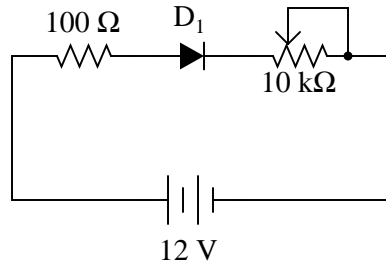

Measuring diode voltage and diode current in this circuit, the student generates the following table of data:

$V_{diode}$	$I_{diode}$
0.600 V	1.68 mA
0.625 V	2.88 mA
0.650 V	5.00 mA
0.675 V	8.68 mA
0.700 V	14.75 mA
0.725 V	27.25 mA
0.750 V	48.2 mA

This student knows that the behavior of a PN junction follows Shockley's diode equation, and that the equation may be simplified to the following form:

$$I_{diode} = I_S(e^{\frac{V_{diode}}{K}} - 1)$$

Where,

$K$  = a constant incorporating both the thermal voltage and the nonideality coefficient

The goal of this experiment is to calculate  $K$  and  $I_S$ , so that the diode's current may be predicted for any arbitrary value of voltage drop. However, the equation must be simplified a bit before the student can proceed.

At substantial levels of current, the exponential term is very much larger than unity ( $e^{\frac{V_{diode}}{K}} \gg 1$ ), so the equation may be simplified as such:

$$I_{diode} \approx I_S(e^{\frac{V_{diode}}{K}})$$

From this equation, determine how the student would calculate  $K$  and  $I_S$  from the data shown in the table. Also, explain how this student may verify the accuracy of these calculated values.

[file 01923](#)

---

Question 129

The nonconducting depletion region of a PN junction forms a parasitic capacitance between the P and the N semiconductor region. Does the capacitance increase or decrease as a greater reverse-bias voltage is applied to the PN junction? Explain your answer.

[file 00899](#)

---

Question 130

An important parameter for many semiconductor components is *thermal resistance*, usually specified in units of degrees Celsius per Watt. What does this rating mean, and how is it related to temperature?

[file 00922](#)

---

Question 131

Rectifying diodes, like many other types of semiconductor components, should be *derated* at elevated ambient temperatures. Datasheets often provide "derating curves" that prescribe the maximum current for a range of ambient temperatures.

Explain just what "derating" is, and why it is so important for semiconductor devices.

[file 00950](#)

The following schematic diagram is of a simple *curve tracer circuit*, used to plot the current/voltage characteristics of different electronic components on an oscilloscope screen:

*Simple curve tracer circuit*

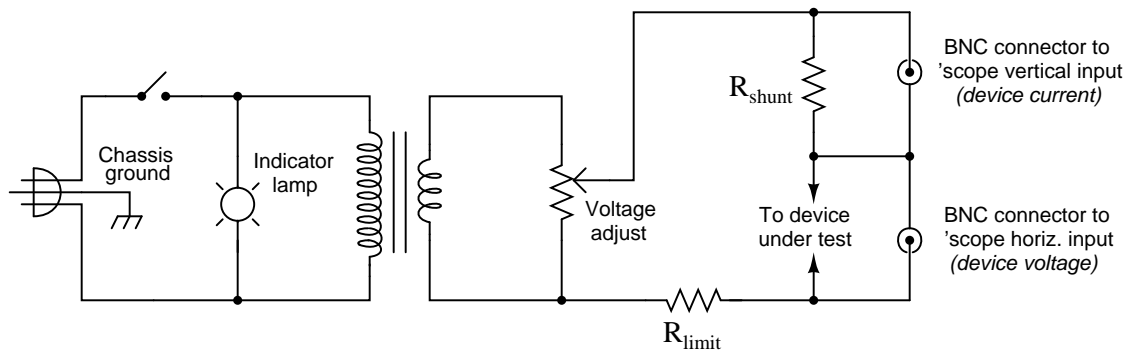

The way it works is by applying an AC voltage across the terminals of the device under test, outputting two different voltage signals to the oscilloscope. One signal, driving the horizontal axis of the oscilloscope, represents the voltage across the two terminals of the device. The other signal, driving the vertical axis of the oscilloscope, is the voltage dropped across the shunt resistor, representing current through the device. With the oscilloscope set for "X-Y" mode, the electron beam traces the device's characteristic curve.

For example, a simple resistor would generate this oscilloscope display:

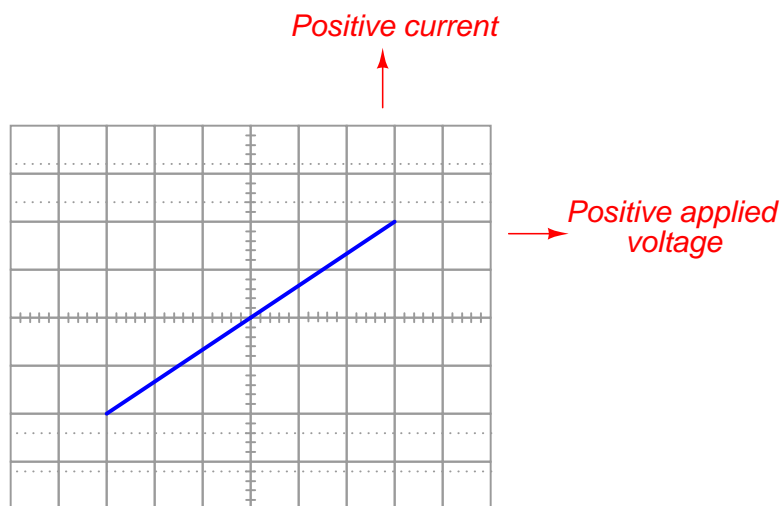

A resistor of greater value (more ohms of resistance) would generate a characteristic plot with a shallower slope, representing less current for the same amount of applied voltage:

*Higher-valued resistor*

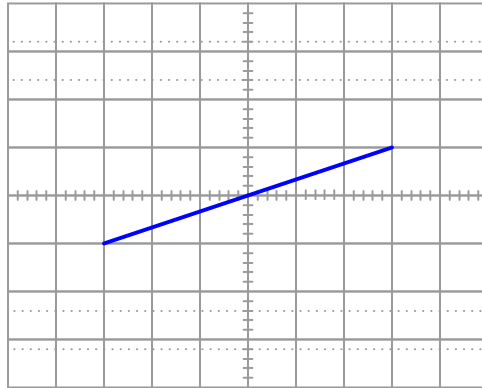

Curve tracer circuits find their real value in testing semiconductor components, whose voltage/current behaviors are nonlinear. Take for instance this characteristic curve for an ordinary rectifying diode:

*Rectifying diode curve*

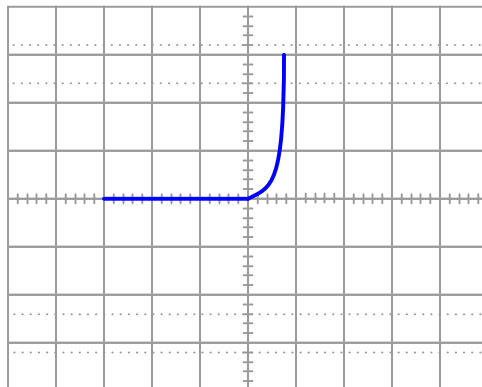

The trace is flat everywhere left of center where the applied voltage is negative, indicating no diode current when it is reverse-biased. To the right of center, though, the trace bends sharply upward, indicating exponential diode current with increasing applied voltage (forward-biased) just as the "diode equation" predicts.

On the following grids, plot the characteristic curve for a diode that is failed shorted, and also for one that is failed open:

*Diode failed shorted*

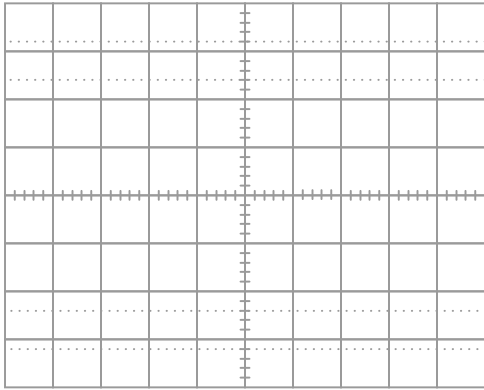

*Diode failed open*

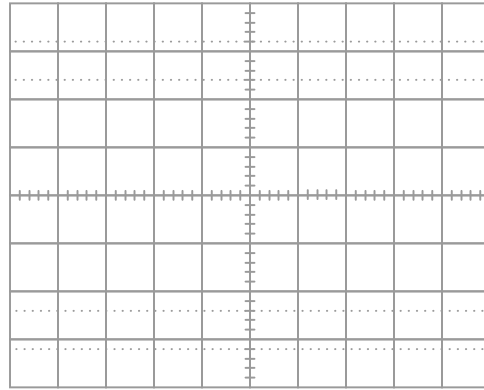

file 02431

Question 133

When plotted on a curve tracer, the characteristic curve for a normal PN junction rectifying diode looks something like this:

*Rectifying diode curve*

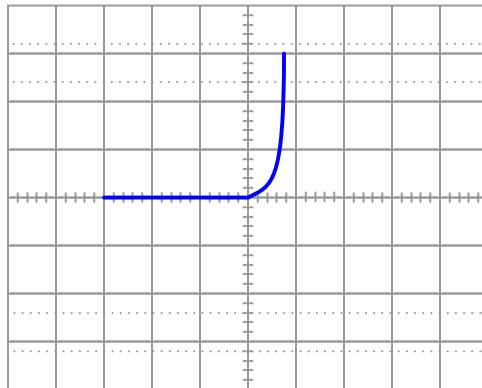

Label each axis (horizontal and vertical) of the curve tracer graph, then determine whether the diode behaves more like a voltage source or more like a current source (i.e. does it try to maintain constant voltage or does it try to maintain constant current?) when it is conducting current.

Models are very useful because they simplify circuit approximations. For example, we can analyze this diode circuit quite easily if we substitute an electrical source in place of the diode:

*Original circuit*

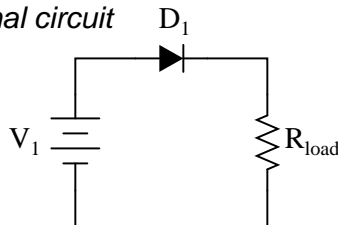

*Should we model the diode as . . . ?*

*A voltage source?*

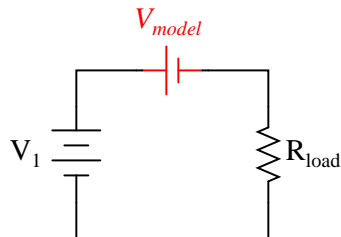

*. . . or as . . .*

*A current source?*

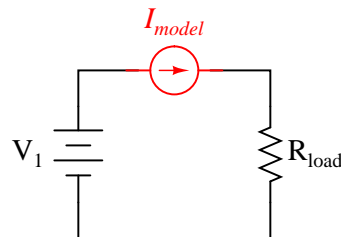

The only question here is, which substitution makes the most sense? Based on the diode's characteristic curve behavior, should we substitute a voltage source or a current source in place of it? Assuming this is a 1N4001 rectifying diode, what is the value we should use for the substituting source?

[file 03128](#)

---

Question 134

What diode performance parameter establishes the limit for maximum frequency of AC which it may rectify? If you were to examine a diode datasheet, what parameter (or parameters) would be the most important in answering this question?

[file 00951](#)

---

Question 135

Explain the operating principle of a *photovoltaic cell*, otherwise known as a "solar cell." What happens within these devices to convert sunlight directly into electricity?

[file 01029](#)

---

Question 136

Explain how the characteristic curve of a 24 volt zener diode (as plotted by a curve tracer) differs from that of a normal rectifying diode, shown here:

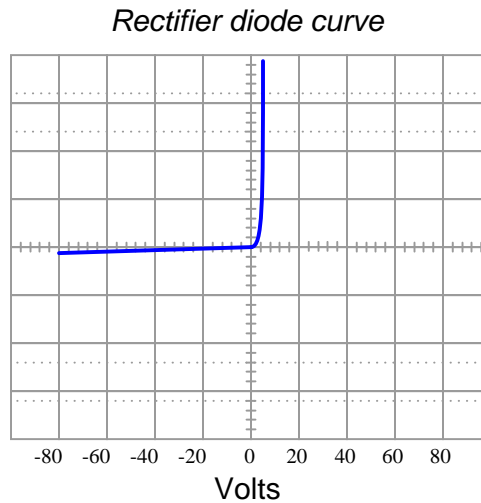

[file 02436](#)

---

Question 137

Suppose you needed to build a simple voltage regulator circuit with a regulation point of 4.5 volts, but had no zener diodes to work with. Can you think of a way normal diodes could be used for the purpose instead?

[file 01063](#)

---

Question 138

Prior to the advent of zener diodes, *gas-discharge* tubes and bulbs were commonly used as voltage regulating devices.

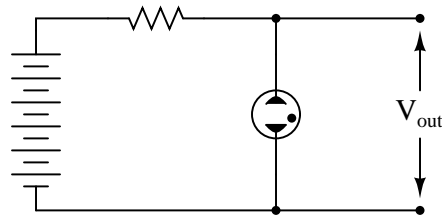

Explain how such a device regulates voltage, and comment on whether or not this type of device is still practical in modern circuit design.

[file 01064](#)

---

Question 139

Calculate the power dissipated by the 5-volt zener diode for the following values of motor current (assume the battery voltage remains constant at 12 volts):

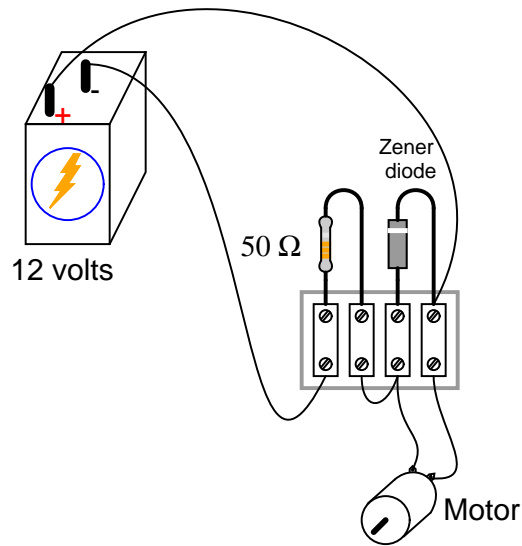

- $I_{motor} = 20 \text{ mA}$  ;  $P_{zener} =$
- $I_{motor} = 50 \text{ mA}$  ;  $P_{zener} =$
- $I_{motor} = 90 \text{ mA}$  ;  $P_{zener} =$
- $I_{motor} = 120 \text{ mA}$  ;  $P_{zener} =$
- $I_{motor} = 150 \text{ mA}$  ;  $P_{zener} =$

[file 00891](#)



---

Question 140

Is it possible to reduce this zener diode voltage regulator circuit to a Thévenin equivalent circuit? Explain why or why not.

*Reduce to a Thevenin equivalent?*

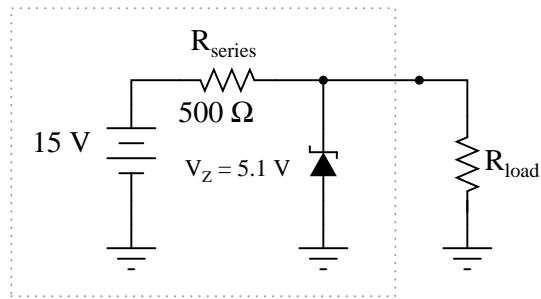

file 02026

---

Question 141

It is possible to purchase *oven-stabilized* zener ICs (integrated circuits). Explain what these are, and what they are useful for.

file 03816

Question 142

When the pushbutton switch is actuated in this circuit, the solenoid valve energizes:

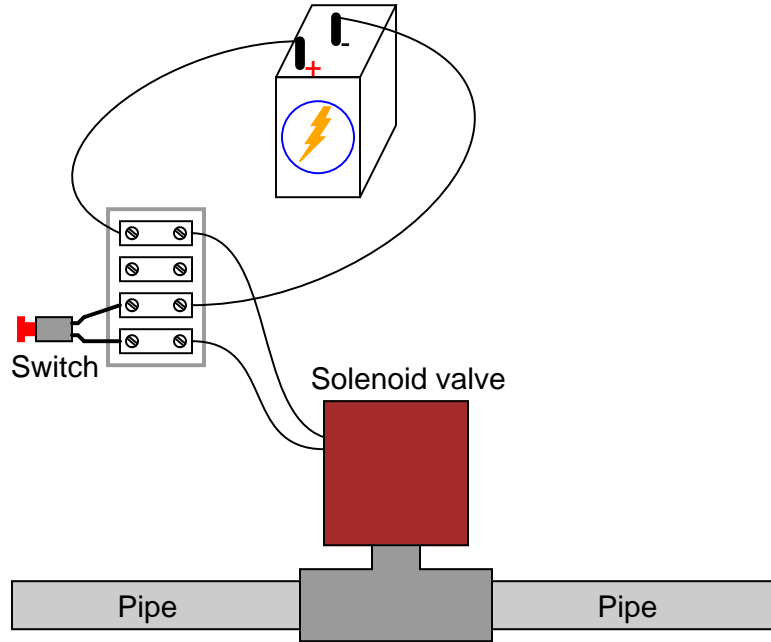

The only problem with this simple circuit is that the switch contacts suffer from extensive arcing caused each time the solenoid is de-energized. One way to combat this arcing, though, is to connect an ordinary rectifying diode in parallel with the solenoid like this:

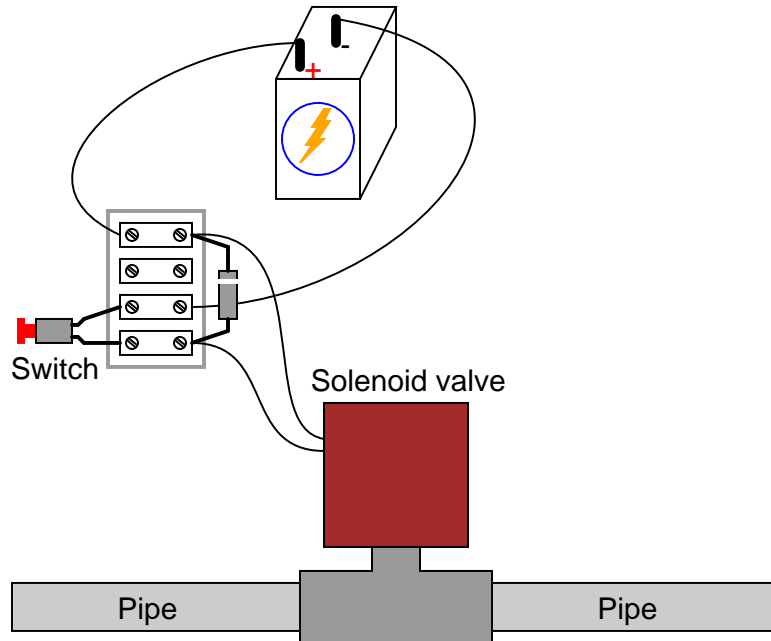

Explain what causes the excessive arcing at the switch contacts, and how the presence of a diode in the circuit completely eliminates it.

[file 00981](#)

---

Question 143

What will an ammeter (with an input resistance of  $0.5\ \Omega$ ) register when connected in *parallel* with the diode in this circuit?

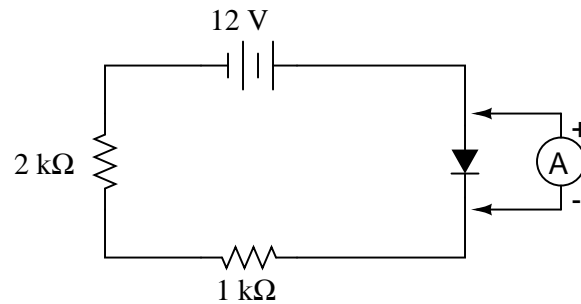

Usually, ammeters are connected in *series* with the component whose current is to be measured. However, in this case a parallel connection is acceptable. Explain why, and determine the ammeter's current reading in this circuit.

[file 00984](#)

---

Question 144

Suppose a very important piece of electronic equipment (nuclear reactor shutdown controls, for instance) needed to be supplied with *uninterruptible* DC power. For reliability's sake, this circuit gets its power from three (redundant) DC voltage sources:

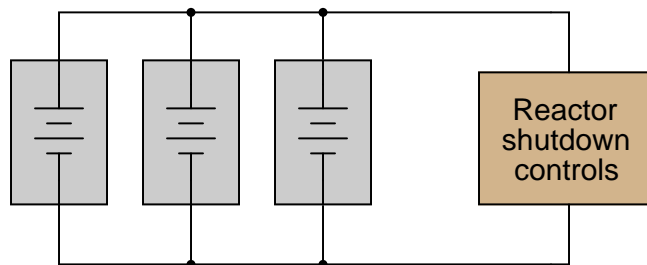

The only problem with this scenario is the possibility of one of these power sources internally short-circuiting. Describe what would happen if one of the three DC power sources developed an internal short-circuit, and explain how this problem could be avoided by placing diodes in the circuit.

[file 00985](#)

$\int f(x) dx$  *Calculus alert!*

A forward-biased PN semiconductor junction does not possess a "resistance" in the same manner as a resistor or a length of wire. Any attempt at applying Ohm's Law to a diode, then, is doomed from the start.

This is not to say that we cannot assign a *dynamic* value of resistance to a PN junction, though. The fundamental definition of resistance comes from Ohm's Law, and it is expressed in derivative form as such:

$$R = \frac{dV}{dI}$$

The fundamental equation relating current and voltage together for a PN junction is Shockley's diode equation:

$$I = I_S(e^{\frac{qV}{nkT}} - 1)$$

At room temperature (approximately 21 degrees C, or 294 degrees K), the thermal voltage of a PN junction is about 25 millivolts. Substituting 1 for the nonideality coefficient, we may simplify the diode equation as such:

$$I = I_S(e^{\frac{V}{0.025}} - 1) \quad \text{or} \quad I = I_S(e^{40V} - 1)$$

Differentiate this equation with respect to  $V$ , so as to determine  $\frac{dI}{dV}$ , and then reciprocate to find a mathematical definition for dynamic resistance ( $\frac{dV}{dI}$ ) of a PN junction. Hints: saturation current ( $I_S$ ) is a very small constant for most diodes, and the final equation should express dynamic resistance in terms of thermal voltage (25 mV) and diode current ( $I$ ).

[file 02538](#)

### Answer 1

"Charge carriers" are any particles possessing an electrical charge, whose coordinated motion through a substance constitutes an electric current. Different types of substances have different charge carriers:

- Metals: "free" (conduction-band) electrons
  - Semiconductors: electrons and holes
  - Liquids: ions
- 

### Answer 2

The fact that atomic electrons inhabit "quantized" energy states is evidenced by the characteristic wavelengths of light emitted by certain atoms when they are "excited" by external energy sources. Rutherford's planetary model could not account for this behavior, thus the necessity for a new model of the atom.

Semiconductor electronics is made possible by the "quantum revolution" in physics. Electrical current travel through semiconductors is impossible to adequately explain apart from quantum theory.

Challenge question: think of an experiment that could be performed in the classroom to demonstrate the characteristic wavelengths emitted by "excited" atoms.

---

### Answer 3

Pauli's Exclusion Principle states that "No two electrons in close proximity may inhabit the exact same quantum state." Therefore, when lots of atoms are packed together in close proximity, their individual electron states shift energy levels slightly to become continuous *bands* of energy levels.

---

### Answer 4

- **Metals** are the best conductors of electricity, because many of their electrons occupy the "conduction band" at normal temperatures.
  - **Insulators** are the worst conductors of electricity, because a tremendous amount of energy must be invested before an electron can "leap" across the large gap into the conduction band.
- 

### Answer 5

Semiconducting substances are defined by the size of the gap between the valence and conduction bands. In elemental substances, this definition is generally met in crystalline materials having four valence electrons. However, other materials also meet the band gap criterion and thus are also semiconductors. A few are listed here:

- Gallium arsenide (GaAs)
- Gallium nitride
- Silicon carbide
- Some plastics (!)

While Gallium Arsenide is broadly used at the time of this writing (2004), the others are mostly in developmental stages. However, some of them show great promise, especially gallium nitride and silicon carbide in applications of high power, high temperature, and/or high frequency.

Answer 6

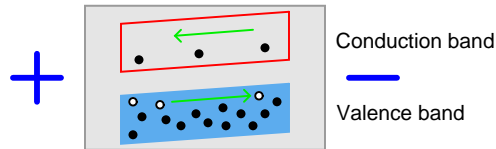

The presence of an electric field across the length of the material will cause the bands to slope, electrons moving toward the positive side and holes toward the negative.

Answer 7

Under the influence of thermal energy from ambient sources, pentavalent "donor" atoms contribute to free electrons in the conduction band:

*Doped with a "pentavalent" impurity*

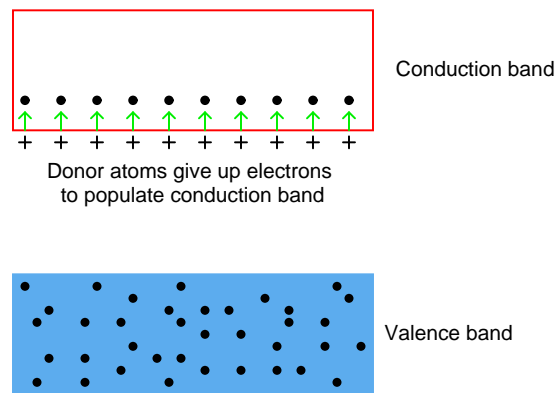

Likewise, trivalent "acceptor" atoms contribute to holes in the valence band:

*Doped with a "trivalent" impurity*

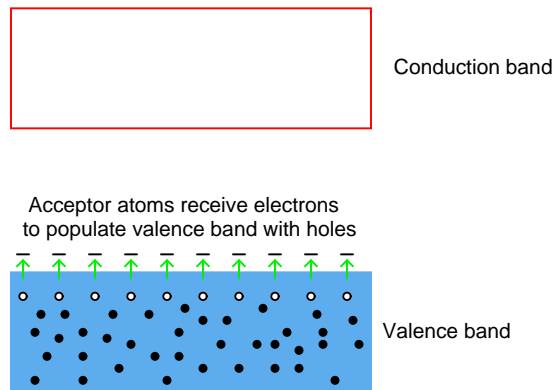

In either case, the addition of impurities to an otherwise pure semiconductor material increases the number of available charge carriers.

---

Answer 8

To create donor electrons, you must add a substance with a greater number of valence electrons than the base semiconductor material. When this is done, it is called an **N-type** semiconductor.

To create acceptor holes, you must add a substance with a lesser number of valence electrons than the base semiconductor material. When this is done, it is called a **P-type** semiconductor.

Follow-up question: identify some common "donor" (N-type) and "acceptor" (P-type) dopants.

---

Answer 9

"Majority carriers" are those charge carriers existing by the purposeful addition of doping elements to the material. "Minority carriers" are the opposite type of charge carrier, inhabiting a semiconductor only because it is impossible to completely eliminate the impurities generating them.

---

Answer 10

The "Fermi level" is the highest energy level that electrons will attain in a substance at a temperature of absolute zero.

---

Answer 11

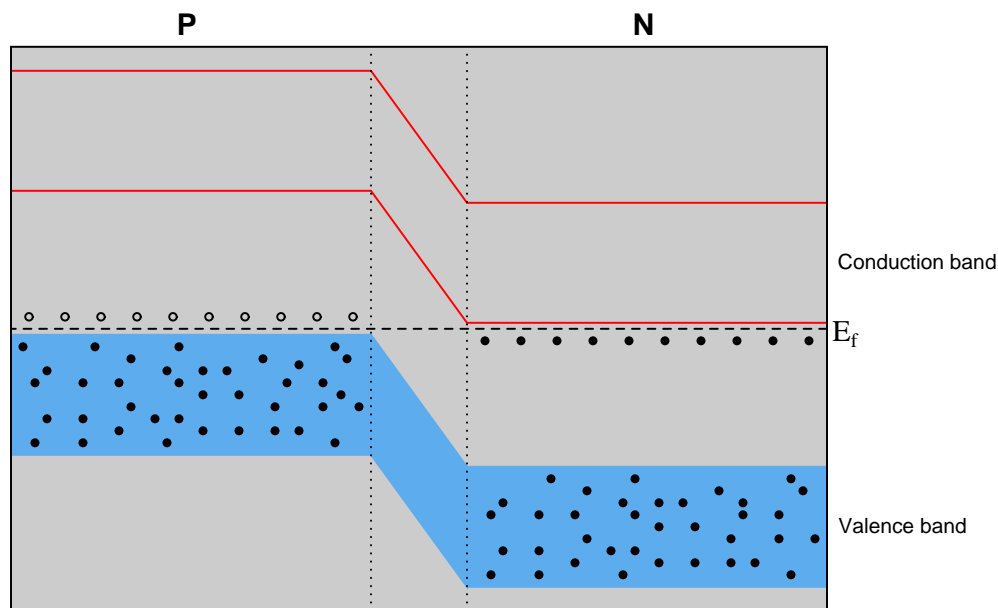

Electrons from the N-piece rushed over to fill holes in the P-piece *in order to achieve a lower energy state* and equalize the two Fermi levels. This displacement of charge carriers created an electric field which accounts for the sloped energy bands in the middle region.

Follow-up question: what is this middle region called?

---

Answer 12

The answer to this question depends entirely on the polarity of the applied voltage! One polarity tends to expand the depletion region, while the opposite polarity tends to compress it. I'll let you determine which polarity performs which action, based on your research.

PN junction under influence of a "reverse" voltage

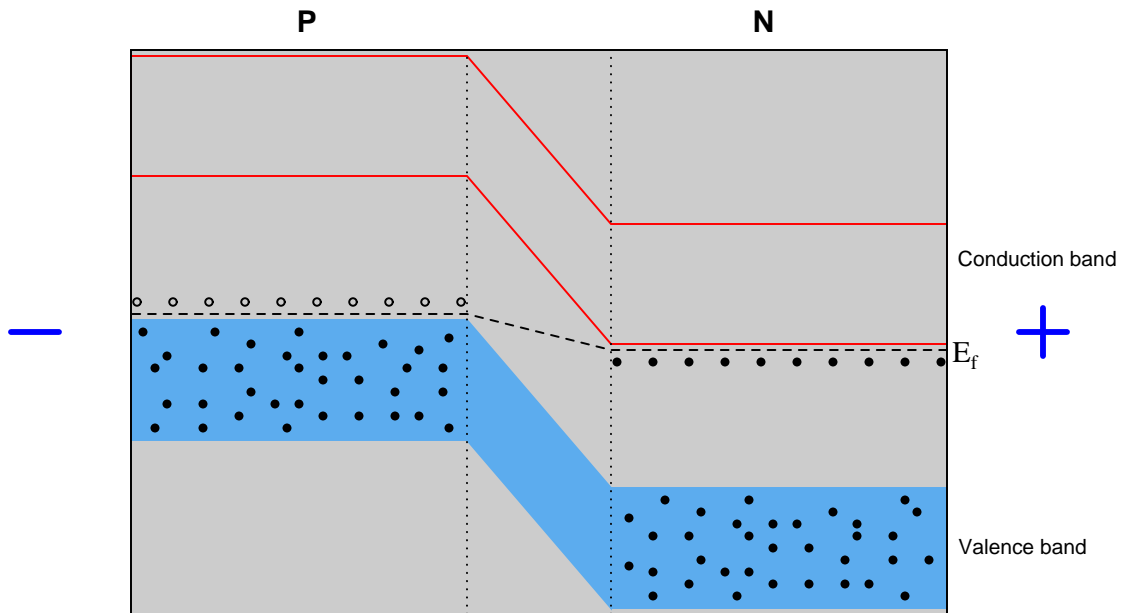

Note:  $E_f$  represents the Fermi energy level, and not a voltage. In physics,  $E$  always stands for energy and  $V$  for electric potential (voltage).



*PN junction under influence of a "forward" voltage*

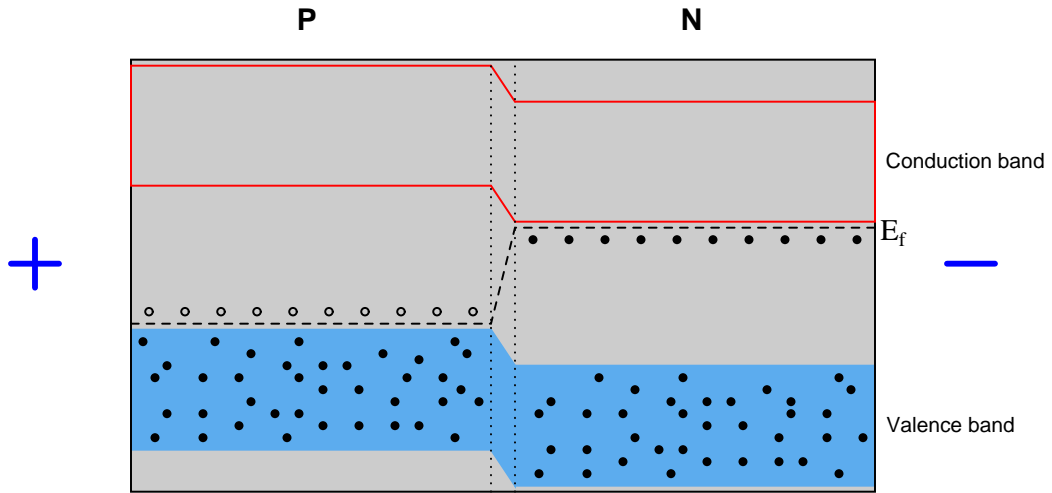

*Note:  $E_f$  represents the Fermi energy level, and not a voltage. In physics,  $E$  always stands for energy and  $V$  for potential (voltage).*

For the sake of clearly seeing the actions of charge carriers (mobile electrons and holes), non-moving electrons in the valence bands are not shown:

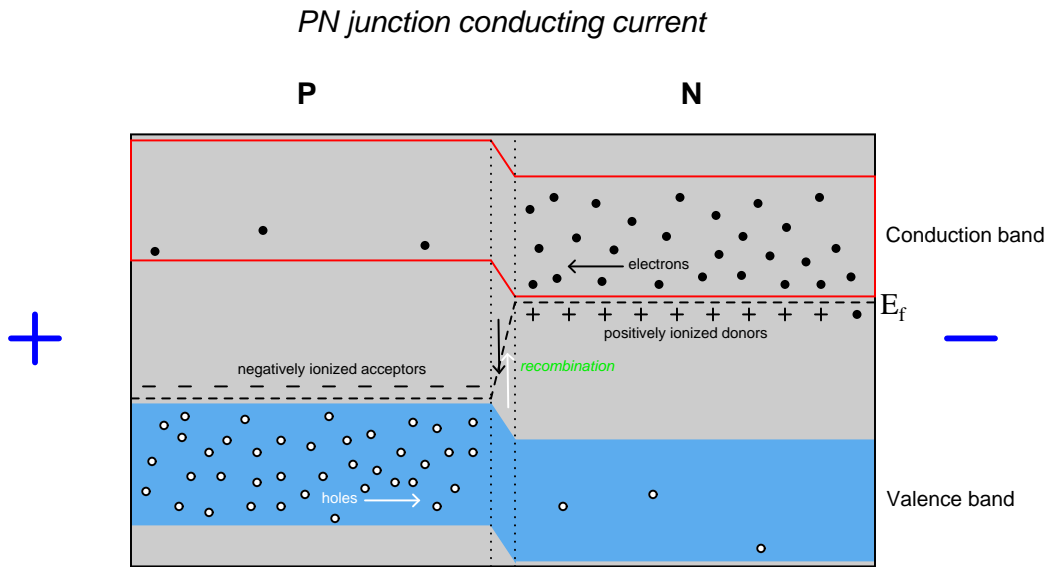

The "+" and "-" signs show the locations of ionized acceptor and donor atoms, having taken on electric charges to create valence-band holes and conduction-band electrons, respectively.

*Note:  $E_f$  represents the Fermi energy level, and not a voltage. In physics,  $E$  always stands for energy and  $V$  for potential (voltage).*

---

Answer 16

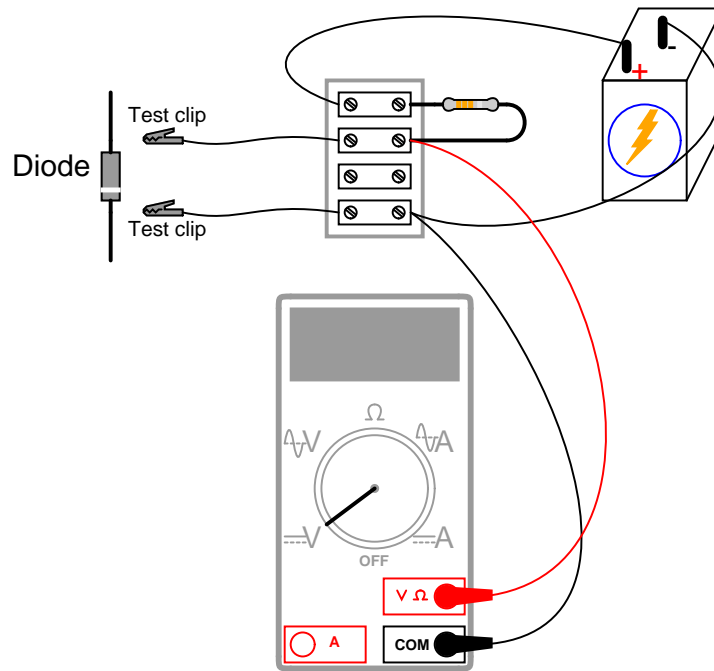

---

Answer 17

Minority carriers allow reverse current through a PN junction.

---

Answer 18

Simplified proportionality:

$$I_D \propto e^{V_D}$$

The graph described by the "diode formula" is a standard exponential curve, rising sharply as the independent variable ( $V_D$ , in this case) increases. The corresponding graph for a resistor, of course, is linear.

---

Answer 19

Silicon = 0.7 volts ; Germanium = 0.3 volts.

Temperature, current, and doping concentration all affect the forward voltage drop of a PN junction.

---

Answer 20

Did you really think I was going to give away the answer here, and spoil the fun of setting up an experiment?

---

Answer 21

I'll give you a hint: there is a stripe (similar to a color band on a resistor) closer to one end of the diode than the other!

---

Answer 22

Only the *reverse* (or *blocking*) voltage rating differs between these diode models.

---

Answer 23

- Good diode: one LED lit
- Diode failed shorted: both LEDs lit
- Diode failed open: neither LED lit

Challenge question: this circuit not only detects the presence of a good diode, but it also has the ability to identify that diode's polarity (which terminal is the cathode, and which terminal is the anode). Explain how the circuit is able to do this.

---

Answer 24

**Resistor curve**  
(with Y channel inverted)

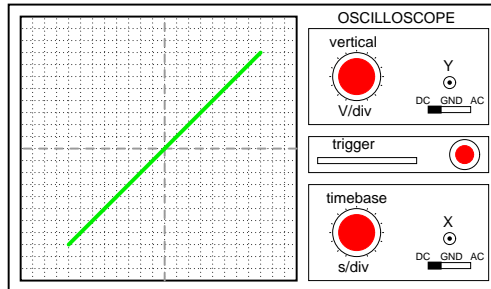

**Diode curve**  
(with Y channel inverted)

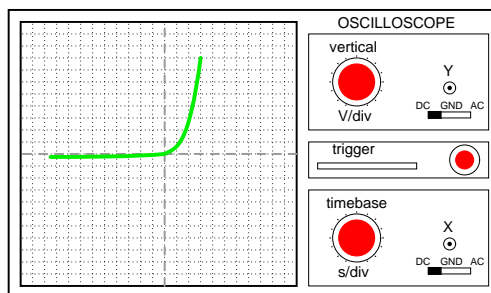

Challenge question: does it matter whether or not the AC source voltage for this circuit is perfectly sinusoidal?

---

Answer 25

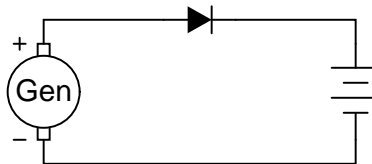

---

Answer 26

Use three 1N4001 diodes connected in parallel, like this:

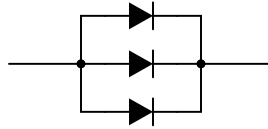

Follow-up question: while this solution should work (in theory), in practice one or more of the diodes will fail prematurely due to overheating. The fix for this problem is to connect "swamping" resistors in series with the diodes like this:

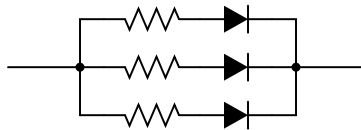

Explain why these resistors are necessary to ensure long diode life in this application.

---

Answer 27

Use seven 1N4002 diodes connected in series, like this:



Follow-up question: while this solution should work (in theory), in practice one or more of the diodes will fail prematurely due to overvoltage. The fix for this problem is to connect "divider" resistors in parallel with the diodes like this:

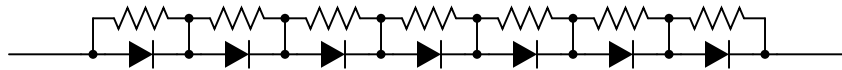

Explain why these resistors are necessary to ensure long diode life in this application.

---

Answer 28

If possible, find a manufacturer's datasheet for your components (or at least a datasheet for a similar component) to discuss with your classmates.

Be prepared to *prove* the forward voltage drop of your diodes in class, by using a multimeter!

---

Answer 29

The motor would vibrate, as the shaft tries to rotate back and forth as quickly as the AC cycles.

---

Answer 30

The motor would spin in one direction, with a pulsing torque.

Follow-up question: identify the polarity of the DC voltage between the motor terminals.

---

Answer 31

The motor would spin in one direction, at least for a short moment in time. Then, something in the circuit (either the diode or the power supply) would fail due to excessive current!

Follow-up question: identify the polarity of the DC voltage between the motor terminals, during that brief period of time where all component are still functioning.

---

Answer 32

With the switch in the "dim" position, the light bulb only receives power for one-half of the AC cycle.

Follow-up question: does it matter which way the diode is oriented in the circuit? If we reversed its connections, would the light bulb behave any differently?

---

Answer 33

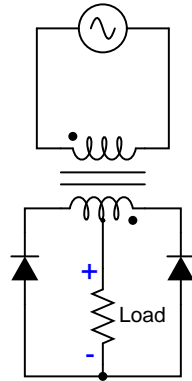

---

Answer 34

Only one-half of the secondary winding powers the load at any given time.

This is a full-wave rectifier circuit.

Challenge question: what would have to change in this circuit to make it a half-wave rectifier?

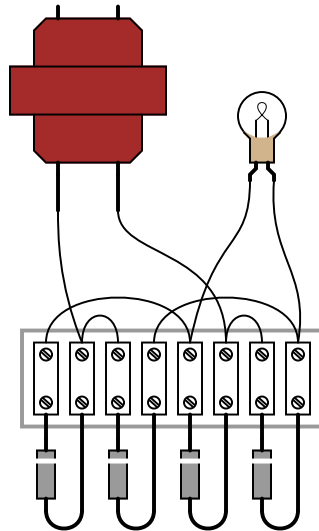

Follow-up question: draw the direction of currents through the bridge rectifier for each half-cycle of the AC power source, and determine the DC voltage polarity across the light bulb terminals.

Note: the voltage readings shown by the voltmeters are *approximate* only!

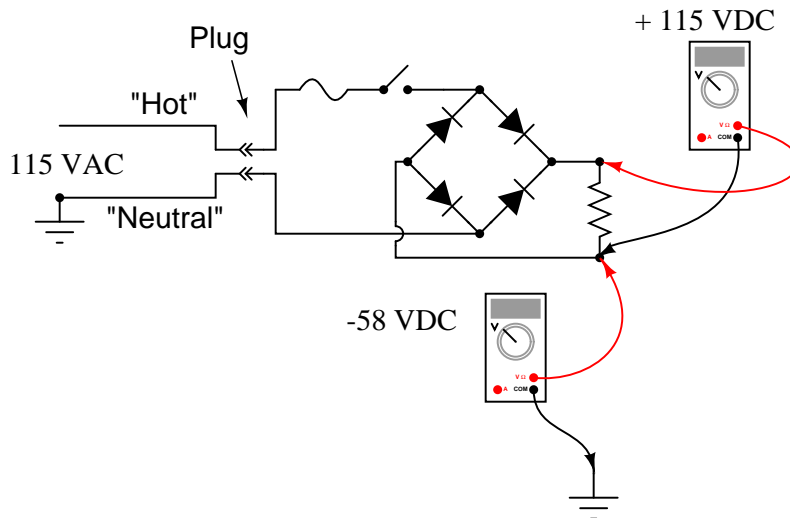

Challenge question: how could the 58 volts from (-) to ground be eliminated, so as to permit grounding of the (-) output terminal?

The oscilloscope's "ground" clip (the alligator-style clip that serves as the second electrical connection point on the probe) is electrically common to the metal chassis of the oscilloscope, which in turn is electrically common with the safety ground conductor of the 120 volt AC power system.

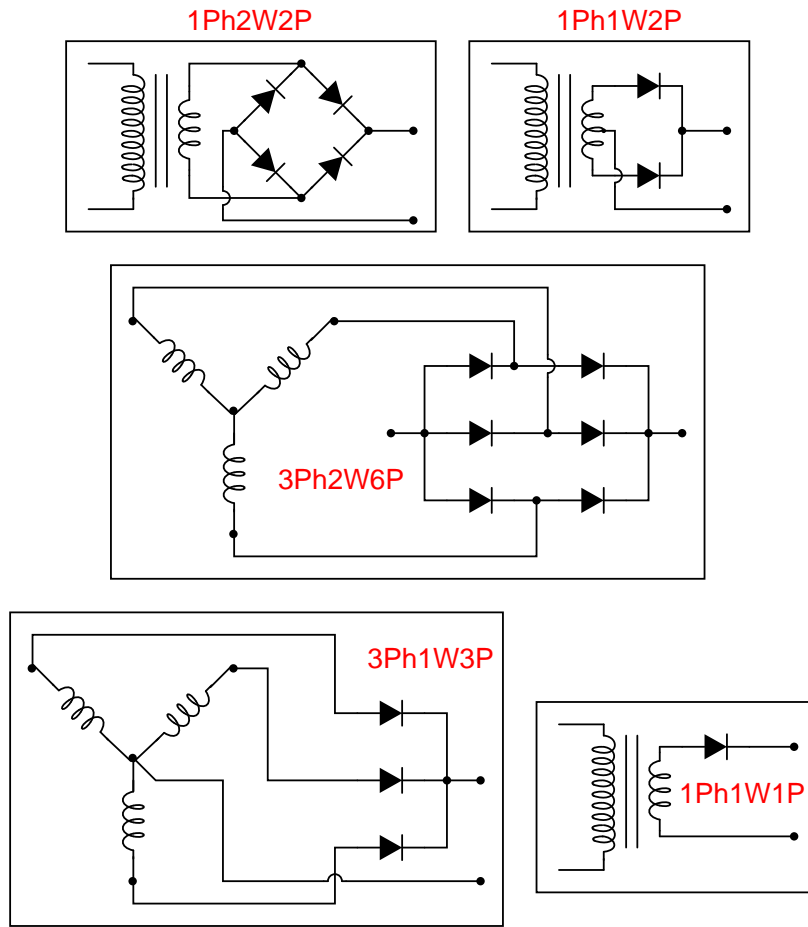

The four-diode bridge rectifies the AC load's current into DC for the transistor to control.



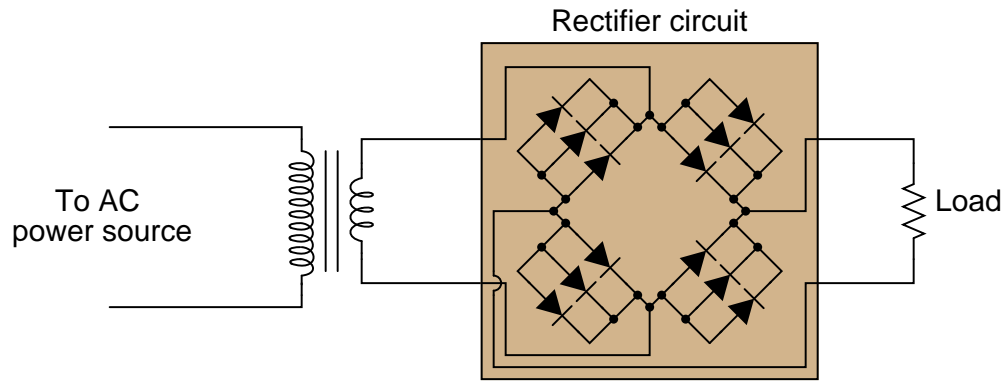

Follow-up question: while this circuit should work (in theory), in practice one or more of the diodes will fail prematurely due to overheating. The fix for this problem is to connect "swamping" resistors in series with the diodes like this:

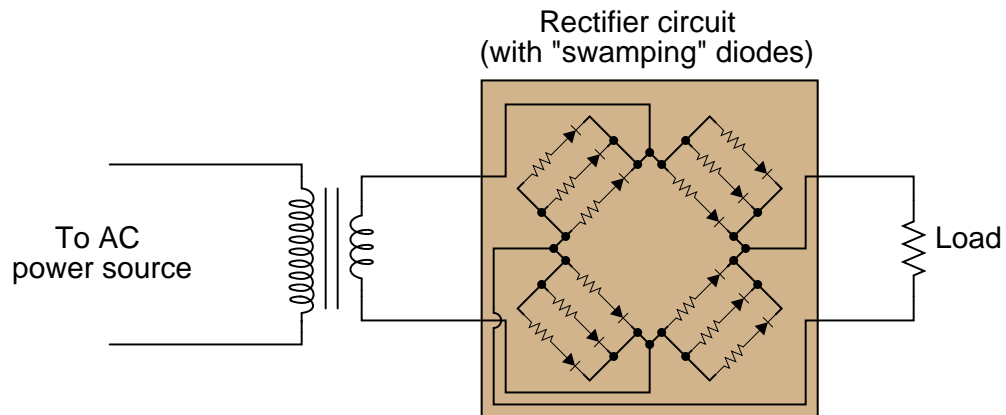

Explain why these resistors are necessary to ensure long diode life.

Most electric power distribution systems are AC, yet most electronic circuits function on DC power.

Transformers provide voltage/current ratio transformation, and also electrical isolation between the AC line circuit and the DC circuit. The issue of isolation is a safety concern, as neither of the output conductors in a non-isolated (direct) rectifier circuit is at the same potential as either of the line conductors.

Follow-up question: explain in detail how the issue of non-isolation could create a safety hazard if this rectifier circuit were energized by an earth-grounded AC line circuit.

---

Answer 43

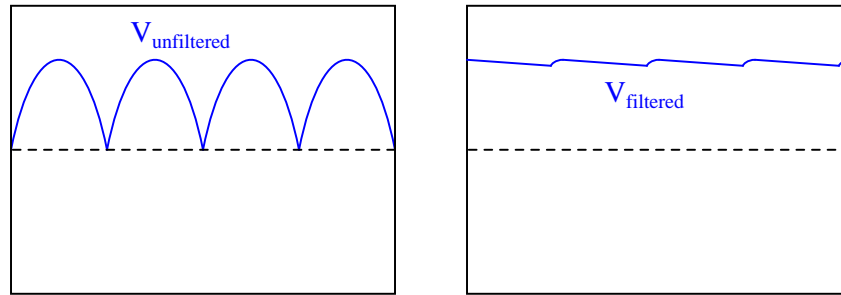

A low pass filter is the kind needed to filter "ripple voltage" from the power supply output.

---

Answer 44

The problem is that the vertical axis input is DC-coupled.

Follow-up question: predict the *frequency* of the ripple voltage in this power supply circuit.

---

Answer 45

The left-hand waveform was measured during a period of heavier loading.

---

Answer 46

This means the peak-to-peak ripple voltage is equal to 5% of the DC (average) voltage.

---

Answer 47

For linear power supplies (those designs having a transformer-rectifier-filter topology), the parameters determining ripple frequency are line frequency and rectification pulses.

---

Answer 48

$V_{\text{out}} = 19.6$  volts

$$V_{\text{out}} = \frac{V_{\text{in}}}{0.707r} - 2V_f$$

Where,

$V_{\text{out}}$  = DC output voltage, in volts

$V_{\text{in}}$  = AC input voltage, in volts RMS

$r$  = Transformer step-down ratio

$V_f$  = Forward voltage drop of each diode, in volts

Follow-up question: algebraically manipulate this equation to solve for  $V_{\text{in}}$ .

---

Answer 49

This means the difference between no-load output voltage and full-load output voltage is 2% of the full-load output voltage.

---

Answer 50

The (unfiltered) output voltage will be half-wave, not full-wave.

---

Answer 51

”Remove all diodes from the circuit and test them individually” is not an acceptable answer to this question. Think of a way that they could be checked while in-circuit (ideally, without having to shut off power to the circuit).

---

Answer 52

The resistor  $R$  tends to limit the output current, resulting in less-than-optimal voltage regulation (the output voltage ”sagging” under load). Better filter configurations include all forms of LC ripple filters, including the popular ”pi” ( $\pi$ ) filter.

Follow-up question: in some applications – especially where very large filter capacitors are used – it is a *good* idea to place a series resistor before the capacitor. Such a resistor is typically rated at a low value so as to not cause excessive output voltage ”sag” under load, but its resistance does serve a practical purpose. Explain what this purpose might be.

---

Answer 53

1.  $V_{TP1-TP2} = 120$  volts AC
2.  $V_{TP1-TP3} = 120$  volts AC
3.  $V_{TP2-TP3} = 0$  volts
4.  $V_{TP4-TP5} = 12.63$  volts AC
5.  $V_{TP5-TP6} = 12.63$  volts AC
6.  $V_{TP7-TP8} = 16.47$  volts DC
7.  $V_{TP9-TP10} = 16.47$  volts DC

---

Answer 54

The fuse is blown open.

Follow-up question: with regard to the troubleshooting technique, this technician seems to have started from one end of the circuit and moved incrementally toward the other, checking voltage at almost every point in between. Can you think of a more efficient strategy than to start at one end and work slowly toward the other?

---

Answer 55

The transformer has an open winding.

Follow-up question #1: with regard to the troubleshooting technique, this technician seems to have started from one end of the circuit and moved incrementally toward the other, checking voltage at almost every point in between. Can you think of a more efficient strategy than to start at one end and work slowly toward the other?

Challenge question: based on the voltage measurements taken, which do you think is the more likely failure, an open primary winding or an open secondary winding?

Follow-up question #2: how could you test the two windings of the transformer for a possible open fault? In other words, is there another type of measurement that could verify our hypothesis of a failed winding?

---

Answer 56

There is an "open" fault between TP4 and TP6.

Follow-up question: with regard to the troubleshooting technique, this technician seems to have started from one end of the circuit and moved incrementally toward the other, checking voltage at almost every point in between. Can you think of a more efficient strategy than to start at one end and work slowly toward the other?

---

Answer 57

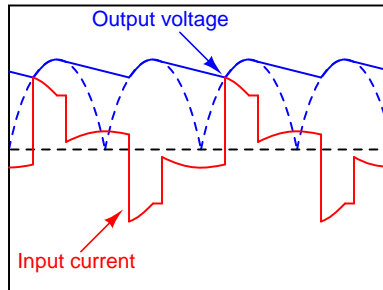

Challenge question: does the input current waveform shown here contain even-numbered harmonics (i.e. 120 Hz, 240 Hz, 360 Hz)?

---

Answer 58

$$X_L = 0.0377 \Omega \text{ (each)}$$

$$X_C = 120.6 \text{ k}\Omega \text{ (each)}$$

---

Answer 59

The diode's peak inverse voltage ("PIV") rating is insufficient. It needs to be about 85 volts or greater in order to withstand the demands of this circuit.

Follow-up question: suggest a part number for a diode capable of withstanding the reverse voltage generated by this circuit, and able to handle at least 1 amp of continuous current.

---

Answer 60

Examples of "split" or "dual" power supply schematic diagrams abound in textbooks. I'll let you do the research here and present your answer(s) during class discussion!

---

Answer 61

A Schottky diode, otherwise known as a *hot carrier* diode, is formed by a junction of metal and N-type semiconducting material. These diodes have less forward voltage drop, faster reverse-recovery time, more reverse leakage current, and less reverse voltage capability than regular PN junction diodes.

---

Answer 62

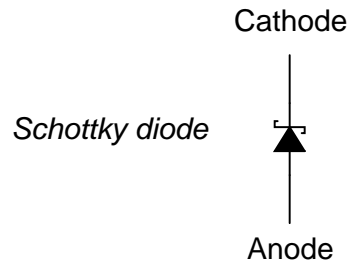

I'll let you research some of the typical applications of Schottky diodes.

---

Answer 63

PN junctions emit energy of a characteristic wavelength when conducting current. For some types of PN junctions, the wavelengths are within the visible range of light.

Follow-up question: what practical application can you think of for this phenomenon?

---

Answer 64

The type of semiconductor materials used to make the PN junction determine the color of light emitted.

Challenge question: describe the relationship between LED color and typical forward voltage, in terms of photon frequency, energy, and semiconductor band gap.

---

Answer 65

LED forward current is 20 mA. Forward voltage varies with color.

---

Answer 66

$R_{dropping} = 1115 \Omega$ , with a power rating of at least 0.446 watts (1/2 watt would be ideal).

Follow-up question: if there were no 1115  $\Omega$  resistors to choose from (which there most likely will not be!), would it be safer to choose a higher-value resistor or a lower-value resistor for this application? For example, if your only choices in 1/2 watt resistors were a 1 k $\Omega$  and a 1.2 k $\Omega$ , which one would you choose? Explain your answer.

---

Answer 67

$C_j$  is inversely related to  $V$  for a varactor diode.

Follow-up question: substitute the varactor diode capacitance equation into the standard resonant frequency equation to arrive at one equation solving for frequency in terms of  $L$  and diode voltage  $V$ .

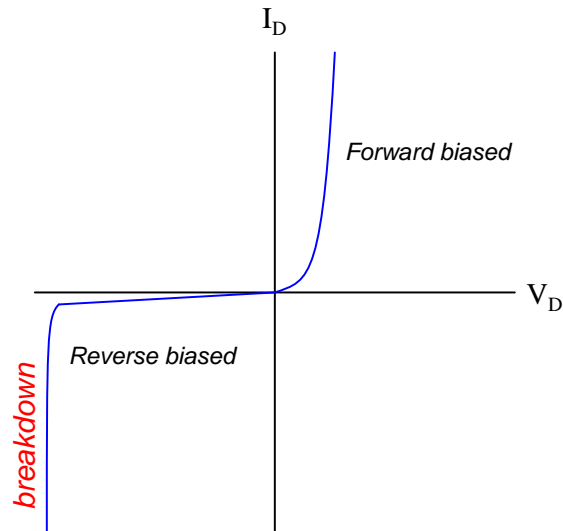

Challenge question: identify where the diode's *reverse saturation current* may be found on this graph.

---

Answer 69

Zener diodes break down at substantially lower reverse voltages than rectifying diodes, and their breakdown voltages are predictable.

---

Answer 70

In order to increase the load voltage, you must decrease the resistance of the rheostat. In order for this scheme to work, the generator's voltage must be greater than the target load voltage.

Note: this general voltage control scheme is known as *series regulation*, where a series resistance is varied to control voltage to a load.

---

Answer 71

In order to increase the load voltage, you must increase the resistance of the rheostat. In order for this scheme to work, the generator's voltage must be greater than the target load voltage.

Note: this general voltage control scheme is known as *shunt regulation*, where a parallel (shunt) resistance is varied to control voltage to a load.

Follow-up question: assuming the load voltage is maintained at a constant value by an astute rheostat operator despite fluctuations in load current, how would you characterize the current through the generator's windings? Does it increase with load current, decrease with load current, or remain the same? Why?

---

Answer 72

The zener draws more or less current as necessary from the generator (through the series resistor) to maintain voltage at a nearly constant value.

Follow-up question #1: if the generator happens to output some ripple voltage (as all electromechanical DC generators do), will any of that ripple voltage appear at the load, after passing through the zener diode voltage regulator circuit?

Follow-up question #2: would you classify the zener diode in this circuit as a *series* voltage regulator or a *shunt* voltage regulator? Explain your answer.

Challenge question: at what point is the zener diode unable to regulate load voltage? Is there some critical load condition at which the diode ceases to regulate voltage?

---

Answer 73

As the load current increases (with less load resistance), zener diode current decreases:

- $R_{load} = 1 \text{ k}\Omega$  ;  $I_{zener} = 14.7 \text{ mA}$
- $R_{load} = 910 \text{ }\Omega$  ;  $I_{zener} = 14.2 \text{ mA}$
- $R_{load} = 680 \text{ }\Omega$  ;  $I_{zener} = 12.3 \text{ mA}$
- $R_{load} = 470 \text{ }\Omega$  ;  $I_{zener} = 8.95 \text{ mA}$
- $R_{load} = 330 \text{ }\Omega$  ;  $I_{zener} = 4.35 \text{ mA}$

Follow-up question: what value of load resistance will result in *zero* current through the zener diode (while still maintaining an output voltage of 5.1 volts)?

---

Answer 74

As the source voltage decreases, zener diode current also decreases:

- $V_{source} = 25 \text{ V}$  ;  $I_{zener} = 41.49 \text{ mA}$
- $V_{source} = 20 \text{ V}$  ;  $I_{zener} = 30.85 \text{ mA}$
- $V_{source} = 15 \text{ V}$  ;  $I_{zener} = 20.21 \text{ mA}$
- $V_{source} = 10 \text{ V}$  ;  $I_{zener} = 9.58 \text{ mA}$
- $V_{source} = 5 \text{ V}$  ;  $I_{zener} = 0 \text{ mA}$

Follow-up question: what value of source voltage input will result in *zero* current through the zener diode (while still maintaining an output voltage of 5.1 volts)?

---

Answer 75

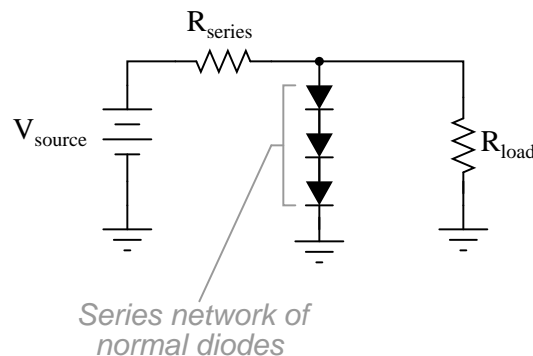

---

Answer 76

There will be no load voltage regulation for any load resistance values *less* than 15 k $\Omega$ .

Follow-up question: calculate the power dissipated by all components in this circuit, if  $R_{load} = 30\text{ k}\Omega$ .

Challenge question: write an equation solving for the minimum load resistance required to maintain voltage regulation.

---

Answer 77

Low-voltage zener diodes have negative temperature coefficients, because they exploit the *zener effect*. High-voltage zener diodes have positive temperature coefficients, because they exploit the *avalanche effect*. I'll let you research how to tell the difference between zener diodes employing each phenomenon on your own!

Challenge question: explain the difference between the "zener" and "avalanche" effects, in terms of charge carrier action.

---

Answer 78

Two zener diodes provide better stability than a single zener diode because the thermal coefficients of the diodes in their respective modes are complementary. This assumes, of course, that the reverse-biased diode uses the *avalanche effect* to regulate voltage.

A functioning voltage regulator circuit might look like this:

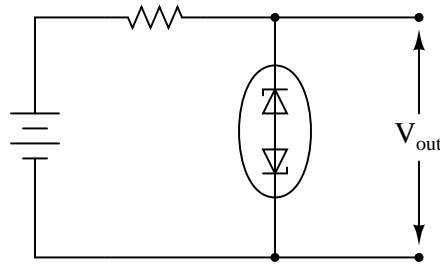

---

Answer 79

This is a nasty, trick question! The physical appearance of any semiconductor component is a poor indication of its identity. Many small zener diodes are packaged in clear bodies, but this does not mean all clear-bodied diodes are zeners, nor that all zeners are found in clear packages! The *part number* of a diode is the only reliable indicator of its identity.

Follow-up question: the physical *size* of a component is often an indication of what performance parameter?

---

Answer 80

$$Z_{zener} = \frac{\Delta E_{diode}}{\Delta I_{diode}} \quad \text{or} \quad Z_{zener} = \frac{dE_{diode}}{dI_{diode}}$$

(The "d" is a calculus symbol, representing a change of infinitesimal magnitude.)

Ideally, a zener diode will have a zener impedance of zero ohms.



---

Answer 81

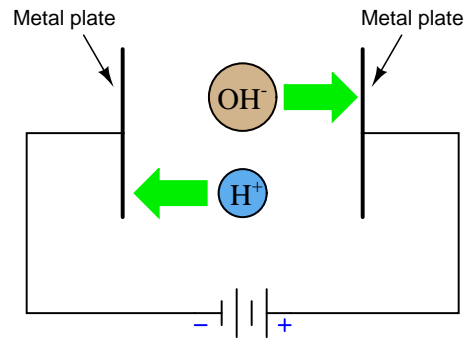

Follow-up question: which of these metal plates would we call the *cathode*, and which would we call the *anode*?

---

Answer 82

This is a "trick" question, as there are two accepted ways of denoting the direction of electric current: *conventional flow* (sometimes called *hole flow*), and *electron flow*.

---

Answer 83

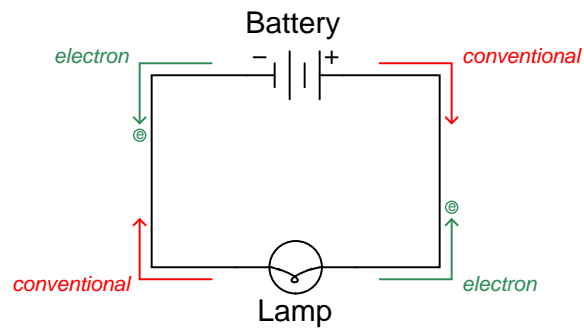

---

Answer 84

One example is conduction in a fluid electrolyte solution, where you often have both positively-charged ions and negatively-charged ions (moving in opposite directions!) constituting the motion of electric charge.

---

Answer 85

I'll let you research this on your own!

The arrowhead represents the presence of a PN junction, the direction of that arrow always pointing in the direction that conventional flow would go if the junction were forward-biased.

The situation is a bit more complex than simply saying that the arrow points in the direction of conventional flow (the standard answer). For a semiconductor device (diode, transistor, thyristor, etc.), an arrowhead represents a PN junction, with the fat end of the arrowhead representing the "P" side and the pointed end representing the "N" side. This much is unambiguous:



*Diode PN junction and symbol*



However, there is at least one device whose *normal* direction of current (in conventional flow) goes *against* this arrow: the zener diode.

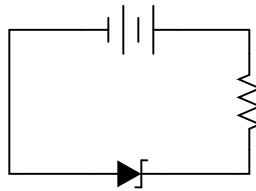

*Zener diode PN junction and symbol*

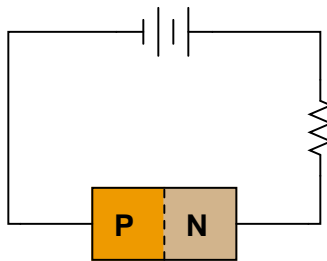

This example can be quite confusing, because the diode is designed to break down in reverse-bias mode. Zener diodes can and will conduct when forward-biased, just like any other diode, but what makes them useful is their reverse-bias behavior. So although it is definitely easier for current to go the "correct" way through a zener diode (arrowhead in the direction of conventional flow), the normal operating direction of current is opposite.

Some semiconductor devices use arrowheads to denote the presence of a non-conducting PN junction. Examples of this include JFETs and MOSFETs:

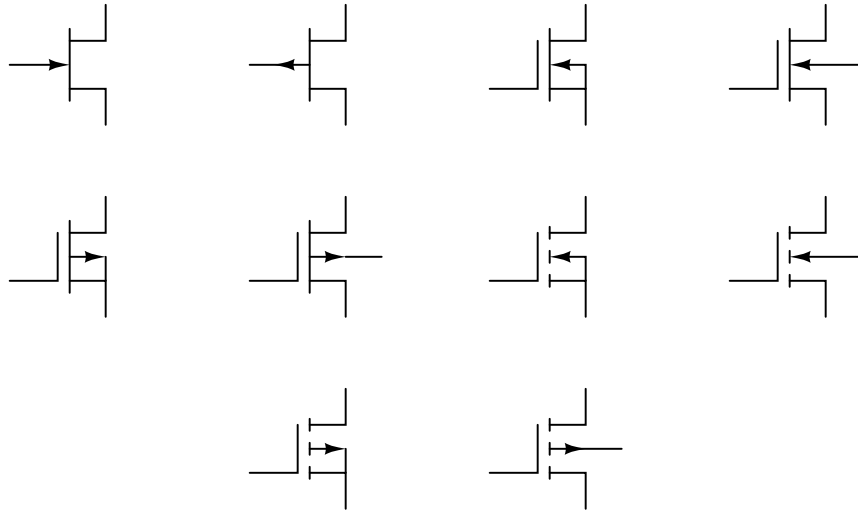

Like the zener diode, the PN junctions shown by the arrowheads in these symbols are designed to operate in reverse-bias mode. Unlike the zener diode, however, the PN junctions within these devices are not supposed to break down, and therefore normally carry negligible current. Here, the arrows represent the direction that conventional flow would go, *provided the necessary applied voltages to forward-bias those junctions*, even though these devices do not normally operate in that mode.

Answer 87

I will let pictures show the answer to this question:

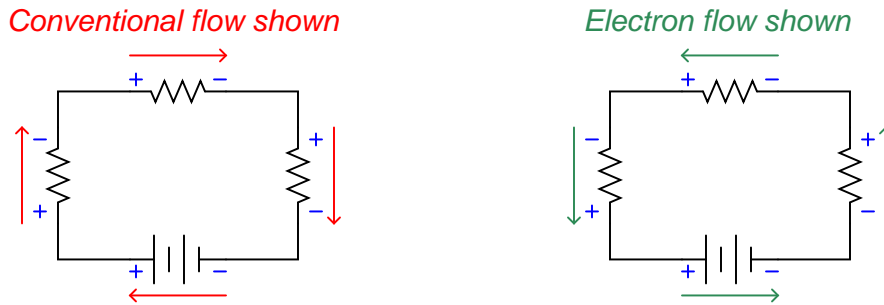

Answer 88

Begin by drawing all currents in the more familiar notation of conventional flow, then reverse each and every arrow!

Answer 89

As with most electron tubes, *electron flow* makes the most sense of a CRT's operation.

**Conventional**



**Electron**



**Conventional**

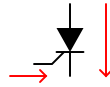

**Conventional**



**Electron**

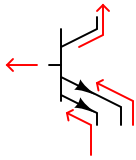

**Electron**

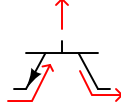

**Electron**

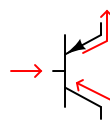

**Conventional**

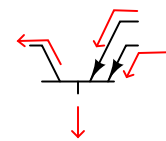

---

Answer 91

Use circuit simulation software to verify your predicted and measured parameter values.

---

Answer 92

Use circuit simulation software to verify your predicted and measured parameter values.

---

Answer 93

Use circuit simulation software to verify your predicted and measured parameter values.

---

Answer 94

Use circuit simulation software to verify your predicted and measured parameter values.

---

Answer 95

Use circuit simulation software to verify your predicted and measured parameter values.

---

Answer 96

Be sure you meet with your instructor if you have any questions about what is expected for your project!

---

Answer 97

- Resistor  $R_1$  fails open:  $V_{TP1} = \text{no change (source voltage)}$ ,  $V_{TP2} = \text{decrease to 0 volts}$ ,  $V_{TP3} = \text{decrease to 0 volts}$ .
- Resistor  $R_2$  fails open:  $V_{TP1} = \text{no change (source voltage)}$ ,  $V_{TP2} = \text{increase to full source voltage}$ ,  $V_{TP3} = \text{decrease to 0 volts}$ .
- Resistor  $R_3$  fails open:  $V_{TP1} = \text{no change (source voltage)}$ ,  $V_{TP2} = \text{increase to full source voltage}$ ,  $V_{TP3} = \text{increase to full source voltage}$ .
- Solder bridge (short) past resistor  $R_2$ :  $V_{TP1} = \text{no change (source voltage)}$ ,  $V_{TP2} = \text{decrease}$ ,  $V_{TP3} = \text{increase}$ ,  $V_{TP2} = V_{TP3}$ .

---

Answer 98

- Diode  $D_1$  fails open: *No current in circuit, no voltage across  $R_1$ , full source voltage across  $D_1$ .*
- Diode  $D_1$  fails shorted: *Increased current in circuit, full source voltage across  $R_1$ , little voltage across  $D_1$ .*
- Resistor  $R_1$  fails open: *No current in circuit, no voltage across  $D_1$ , full source voltage across  $R_1$ .*
- Solder bridge (short) past resistor  $R_1$ : *Large current in circuit, no voltage across  $R_1$ , full source voltage across  $D_1$ ,  $D_1$  will most likely overheat and fail.*

---

Answer 99

- Diode  $D_1$  fails open: *No current in circuit, no voltage across  $R_1$ , no voltage across  $R_2$ , full source voltage across  $D_1$ .*
- Diode  $D_1$  fails shorted: *Increased current in circuit, increased voltage across  $R_1$ , increased voltage across  $R_2$ , little voltage across  $D_1$ .*
- Resistor  $R_1$  fails open: *No current in circuit, no voltage across  $D_1$ , full source voltage across  $R_1$ , no voltage across  $R_2$ .*
- Resistor  $R_2$  fails open: *No current in circuit, no voltage across  $D_1$ , no voltage across  $R_1$ , full source voltage across  $R_2$ .*

---

Answer 100

- Transformer  $T_1$  primary winding fails open: *No current through any component, no voltage across any secondary-side component.*
- Transformer  $T_1$  primary winding fails shorted: *Large current through fuse (which will cause it to blow), little current through secondary winding or load, little voltage across secondary winding or load.*
- Transformer  $T_1$  secondary winding fails open: *No current through any secondary-side component, no voltage across any secondary-winding component, little current through primary winding.*
- Load fails shorted: *Large current through fuse (which will cause it to blow), large current through secondary winding and load, little voltage across secondary winding or load.*

---

Answer 101

- Diode  $D_1$  fails open: *Load resistor receives half-wave rectified power instead of full-wave, more voltage across  $D_1$ .*
- Diode  $D_2$  fails open: *Load resistor receives half-wave rectified power instead of full-wave, more voltage across  $D_2$ .*
- Load resistor fails open: *No current on secondary side of circuit, little current in primary side of circuit, no voltage drop across either  $D_1$  or  $D_2$ .*
- Transformer  $T_1$  primary winding fails open: *No current or voltage anywhere on secondary side of circuit, no current in primary side of circuit.*

---

Answer 102

- Any one diode fails open: *Half-wave rectification rather than full-wave, less DC voltage across load, more ripple (AC) voltage across load.*
- Transformer secondary winding fails open: *no voltage or current on secondary side of circuit after  $C_1$  discharges through load, little current through primary winding.*
- Inductor  $L_1$  fails open: *no voltage across load, no current through load, no current through rest of secondary-side components, little current through primary winding.*
- Capacitor  $C_1$  fails shorted: *increased current through both transformer windings, increased current through diodes, increased current through inductor, little voltage across or current through load, capacitor and all diodes will likely get hot.*

---

Answer 103

Shorted capacitor, open transformer winding (as a result of overloading), shorted diode(s) resulting in blown fuse.

---

Answer 104

- Diode  $D_1$  fails open: *Load receives 2-pulse rectification instead of 3-pulse, increased voltage across  $D_1$ .*
- Generator winding **C** fails open: *Load receives 2-pulse rectification instead of 3-pulse, no current through  $D_3$ .*
- Center connection joining generator windings fails open: *No voltage across any diode or across load, no current through any diode or through load.*

---

Answer 105

- Diode  $D_3$  fails open: *Load receives 5-pulse rectification instead of 6-pulse, increased voltage across  $D_3$ .*
- Generator winding **C** fails open: *Load receives 2-pulse rectification instead of 6-pulse, no current through  $D_5$  or  $D_6$ .*
- Center connection joining generator windings fails open: *No voltage across any diode or across load, no current through any diode or through load.*

---

Answer 106

- Zener diode fails shorted: *Little voltage across load, increased voltage across  $R_{series}$ , increased current through source and  $R_{series}$ .*
- Zener diode fails open: *Increased voltage across load, decreased voltage across  $R_{series}$ , decreased current through source and  $R_{series}$ .*
- Series resistor fails open: *No voltage across  $D_1$  or load, no current through  $D_1$  or load, no current through source.*
- Series resistor fails shorted: *Full source voltage across load and  $D_1$ , greatly increased current through  $D_1$ , increased current through source,  $D_1$  will most likely overheat and fail.*

---

Answer 107

We may express quantities of AC voltage and current in terms of *peak*, *peak-to-peak*, *average*, or *RMS*.

---

Answer 108

50 volts DC applied to a 10  $\Omega$  load will dissipate 250 watts of power. 50 volts (peak, sinusoidal) AC will deliver less than 250 watts to the same load.

---

Answer 109

120 volts AC RMS, *by definition*.

---

Answer 110

The RMS amplitude of this waveform is approximately 0.32 volts.

---

Answer 111

$$\begin{aligned}E_{peak} &= 2.25 \text{ V} \\E_{peak-to-peak} &= 4.50 \text{ V} \\E_{RMS} &= 1.59 \text{ V} \\f &= 40 \text{ Hz}\end{aligned}$$

---

Answer 112

37.5 volts AC, RMS.

---

Answer 113

$$V_{secondary} = 443.7 \text{ volts}$$

---

Answer 114

$$V_{secondary} = 59.6 \text{ volts}$$

---

Answer 115

$$I_{load} = 23.77 \text{ mA} \qquad V_{load} = 8.318 \text{ V}$$

---

Answer 116

$$I_{source} = 187.5 \text{ mA} \qquad I_{load} = 72.73 \text{ mA}$$

---

Answer 117

An "intrinsic" semiconducting material is absolutely pure. An "extrinsic" semiconducting material has dopant(s) added for enhanced conductivity.

---

Answer 118

The more concentrated the "doping," the greater the conductivity of the material.

---

Answer 119

A pentavalent dopant must be added to it, to create donor electrons.

---

Answer 120

A trivalent dopant must be added to it, to create acceptor holes.

---

Answer 121

Semiconducting materials have negative temperature coefficient of resistance ( $\alpha$ ) values, meaning that their resistance decreases with increasing temperature.



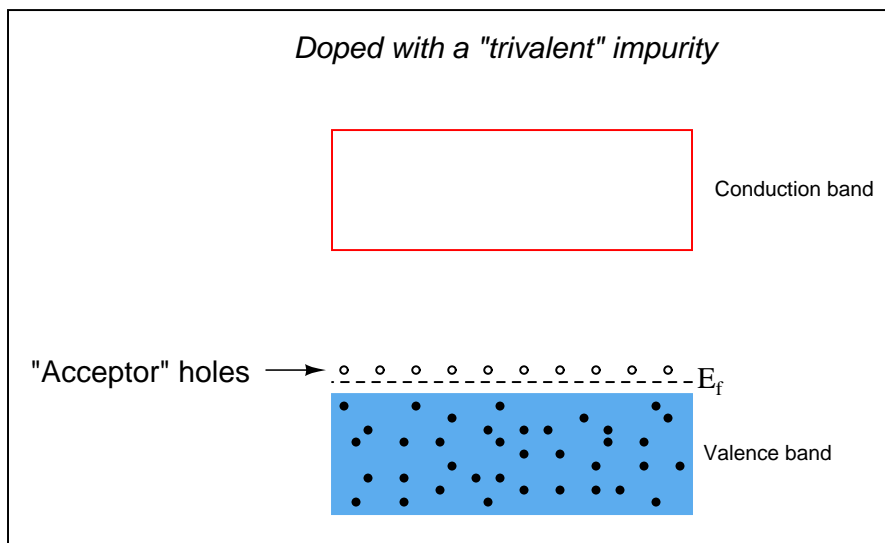
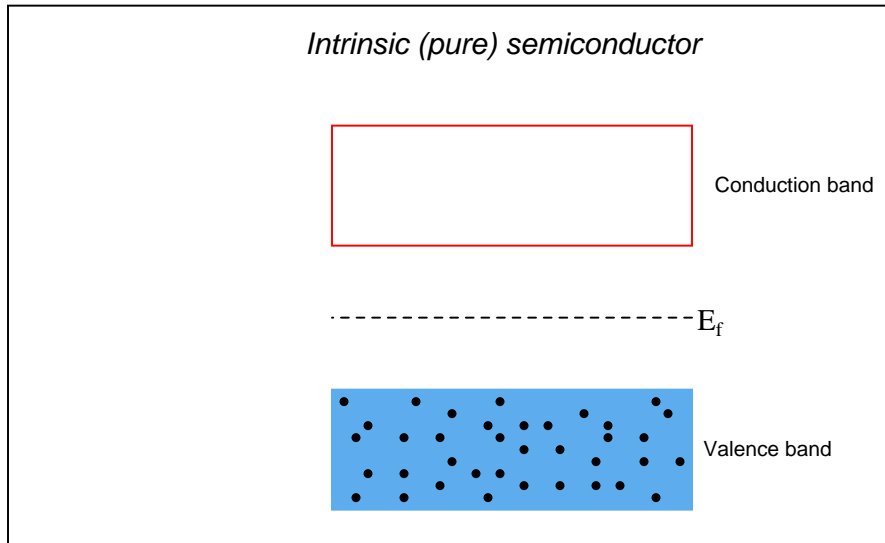

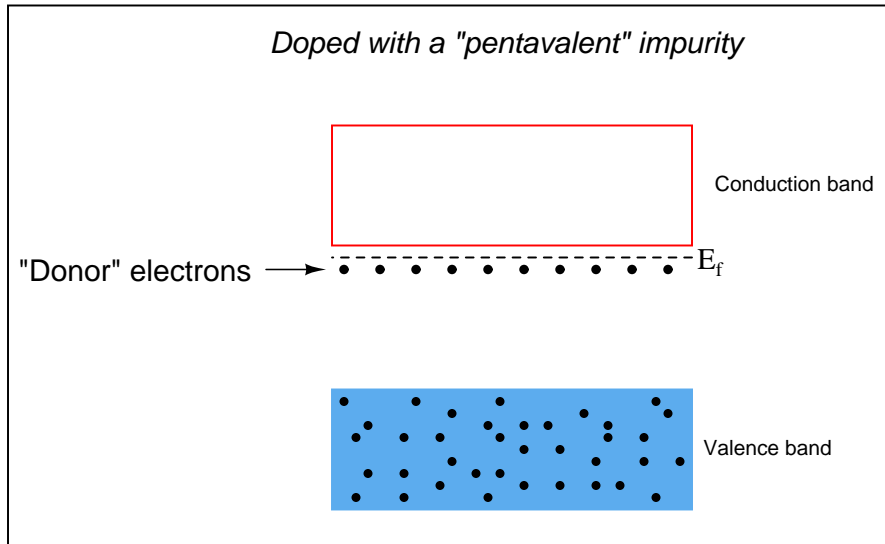

---

Answer 123

The second pulse arose from a "cloud" of holes injected into the N-type germanium bar from the point contact emitter.  $V_{drift}$  provided an electric field to make these holes "drift" from left to right through the bar, where they were eventually detected by the collector point contact.

---

Answer 124

This is called the *depletion region*, and it is essentially an insulator at room temperatures.

---

Answer 125

This diode is reverse-biased.

---

Answer 126

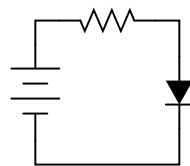

---

Answer 127

If you obtained an answer of 2.16 mV for the "thermal voltage," you have the temperature figure in the wrong units!

$$I_D = I_S(e^{\frac{V_D}{0.0257N}} - 1)$$

---

Answer 128

$$K \approx 0.04516$$
$$I_S \approx 2.869 \text{ nA}$$

Hint: this may be a difficult problem to solve if you are unfamiliar with the algebraic technique of dividing one equation by another. Here is the technique shown in general terms:

$$\text{Given: } y_1 = ax_1 \quad y_2 = ax_2$$

$$\frac{y_1}{y_2} = \frac{ax_1}{ax_2}$$

From here, it may be possible to perform simplifications impossible before. I suggest using this technique to solve for  $K$  first.

Follow-up question: explain how this student knew it was "safe" to simplify the Shockley diode equation by eliminating the "- 1" term. Is this sort of elimination always permissible? Why or why not?

---

Answer 129

The junction capacitance will decrease as the reverse-bias voltage across the junction increases.

Challenge question: can you think of any practical applications for this variable-capacitance effect?

---

Answer 130

"Thermal resistance" is a measure of the heat differential required for a semiconductor component to dissipate a given amount of power.

---

Answer 131

"Derating" means to downgrade the maximum power rating of a component, in a response to changes in other factors affecting the component's operation.

---

Answer 132

*Diode failed shorted*

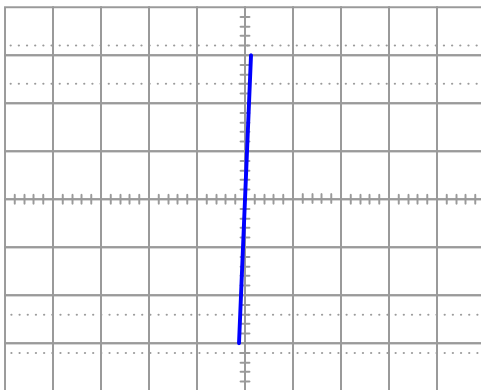

*Diode failed open*

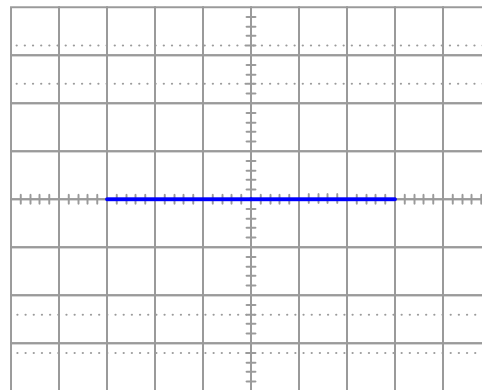

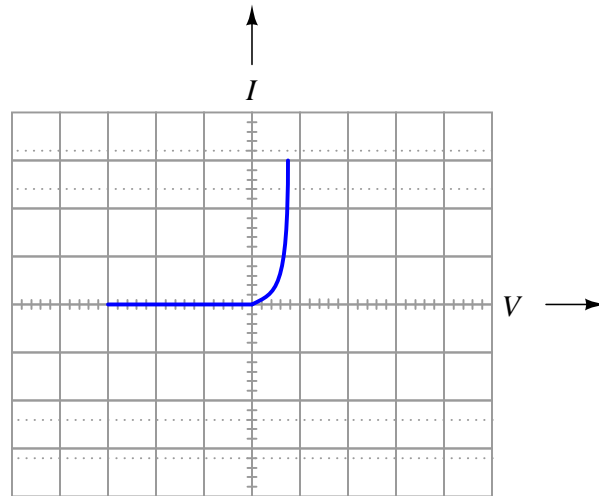

This behavior is similar to that of a voltage source once it is forward-biased and conducting current.

Follow-up question: quite obviously, diodes do not behave exactly as voltage sources. You cannot power anything off of a diode, for instance! Identify some of the limitations inherent to modeling diodes as voltage sources. Are there any instances you can think of where such a model could be misleading?

Answer 134

*Reverse Recovery Time* ( $t_{rr}$ ) is a very important parameter limiting maximum rectification frequency. *Junction capacitance* ( $C_j$ ) is another.

Answer 135

The energy of photons (light "particles") striking a PN semiconductor junction creates electron-hole pairs, which then move in the direction that the depletion region's electric field pushes them.

Challenge question: of what significance is the *band gap* of the PN junction to the efficiency of the cell?

24 volt zener diode curve

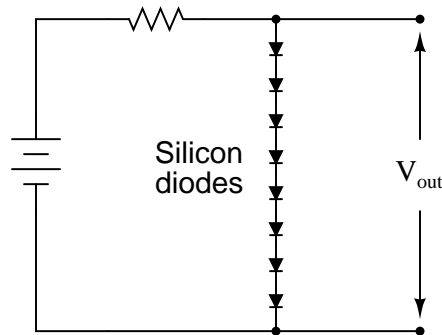
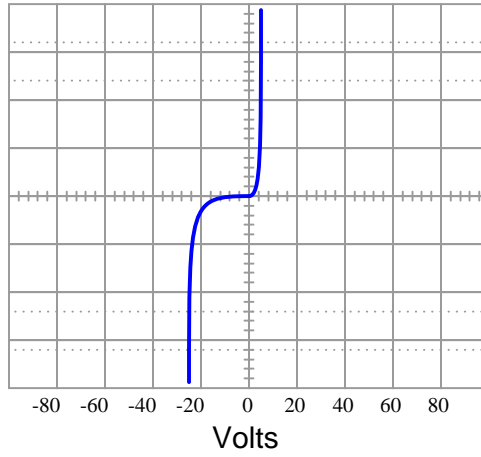

(The number of series-connected diodes required depends on the actual forward voltage drop of each diode under loaded conditions.)

Gas discharge devices, like zener diodes, exploit the sharply vertical portions of their current/voltage transfer functions to regulate voltage over a wide range of current:

Current/voltage function for a "gas discharge" light bulb

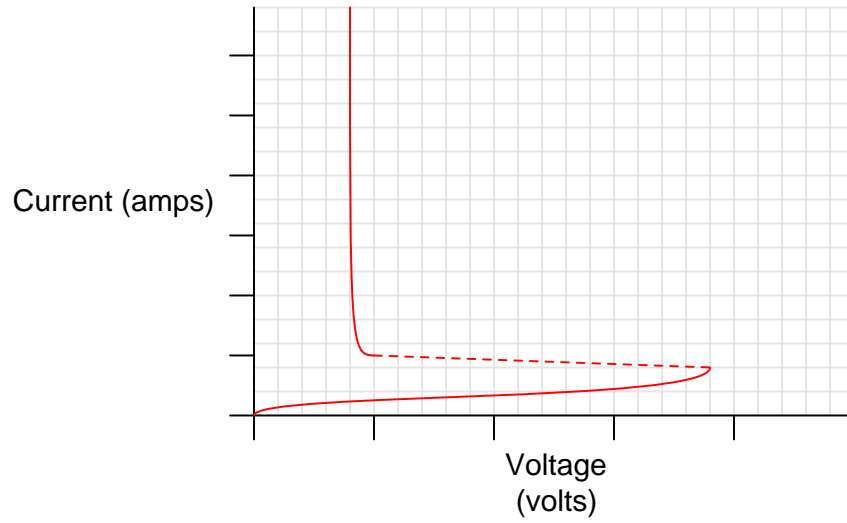

Current/voltage function for a zener diode

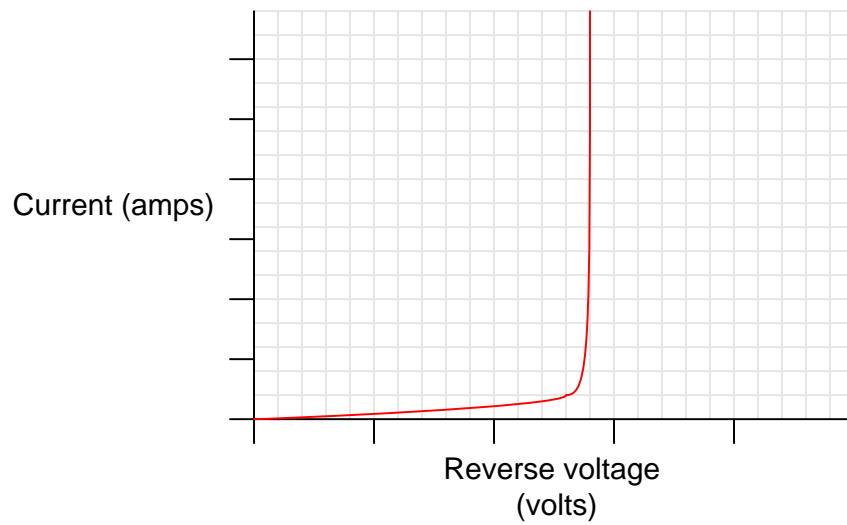

---

Answer 139

- $I_{motor} = 20 \text{ mA}$  ;  $P_{zener} = 600 \text{ mW}$
- $I_{motor} = 50 \text{ mA}$  ;  $P_{zener} = 450 \text{ mW}$
- $I_{motor} = 90 \text{ mA}$  ;  $P_{zener} = 250 \text{ mW}$
- $I_{motor} = 120 \text{ mA}$  ;  $P_{zener} = 100 \text{ mW}$
- $I_{motor} = 150 \text{ mA}$  ;  $P_{zener} = 0 \text{ mW}$

Follow-up question: is load voltage maintained at 5 volts constant throughout this range of load currents (from 20 mA to 150 mA)?

---

Answer 140

Technically, this circuit cannot be reduced to either a Thévenin or Norton equivalent, because the zener diode is a *nonlinear* component. However, it *is* possible to create two different Thévenin equivalent circuits: one representing the circuit when regulating voltage at  $V_{zener}$ , and the other representing the circuit when the load resistance is below the critical value and the voltage is no longer being regulated:

*While regulating at  $V_{zener}$*

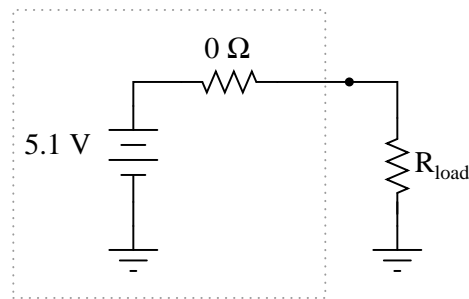

*While overloaded (not regulating)*

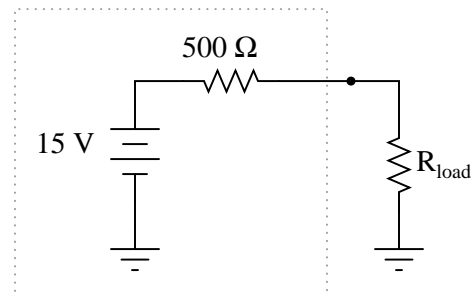

---

Answer 141

Oven-stabilized zeners are used for precision voltage references. I'll let you research how they are constructed and how they function.

---

Answer 142

The arcing is caused by inductive "kickback," and the diode prevents it by providing a complete circuit for the inductor's current to discharge through when the switch opens.

---

Answer 143

The ammeter will register a current of 4 mA.

---

Answer 144

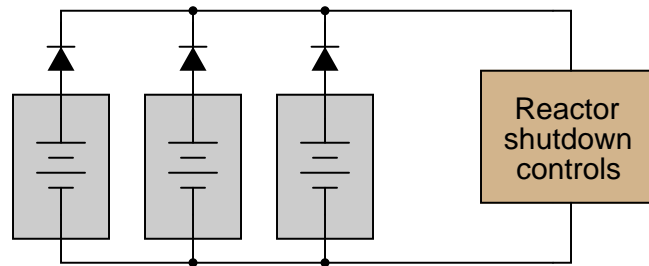

Challenge question: it would be nice if there were indicator lamps in the system to warn maintenance personnel of a shorted power supply. Is there any way you can think of to place light bulbs in this system somewhere, so that one will light up in the event of a power supply failure?

---

Answer 145

$$r \approx \frac{25 \text{ mV}}{I}$$



Notes 1

Metals are by far the simplest materials to understand with reference to electrical conduction. Point out to your students that it is this simplicity that makes metallic conduction so easy to mathematically model (Ohm's Law,  $E = IR$ ).

---

Notes 2

It is no understatement to say that the advent of quantum theory changed the world, for it made possible modern solid-state electronics. While the subject of quantum theory can be arcane, certain aspects of it are nevertheless essential to understanding electrical conduction in semiconductors.

I cringe every time I read an introductory electronics textbook discuss electrons orbiting atomic nuclei like tiny satellites "held in orbit by electrostatic attraction and centrifugal force". Then, a few pages later, these books start talking about valence bands, conduction bands, forbidden zones, and a host of other phenomenon that make absolutely no sense within the planetary model of the atom, but only make sense in a quantum view (where electrons are only "allowed" to inhabit certain, discrete energy states around the nucleus).

In case none of your students are able to answer the challenge question, you may give them this hint: *gas-discharge lamps* (neon, hydrogen, mercury vapor, sodium, etc.)!

---

Notes 3

Ask your students to think of analogies to illustrate this principle. Where else do we see multiple, individual entities joining together to form a larger (continuous) whole?

---

Notes 4

I have given more information in the answer to this question than usual for me, because this subject is rather complex. One of the themes I'm trying to communicate in this question is that semiconductors are not just conductors with an unusually high amount of resistance. The mechanism of conduction in a pure semiconductor is fundamentally different from that of a metal.

Though this can become confusing, electrical conduction in metallic substances actually has two different forms: one where two electron bands overlap (permitting electrons to drift into the upper band and move between atoms), and one where the highest "unexcited" electron band is only partially filled (permitting electrons to drift into the upper regions of that same band and move between atoms). Whether or not this distinction is worthwhile to discuss in detail is a matter for you to decide.

---

Notes 5

I find it frustrating how many introductory electronics texts butcher the subject of semiconductor physics in an effort to "dumb it down" for technician consumption, when in fact these inaccuracies really obfuscate the subject. Furthermore, I have yet to read (October 2004) an introductory text that even bothers to mention substances other than silicon and germanium as semiconductors, despite a great deal of research and development taking place in the field of semiconductor materials

Thankfully, the internet provides a wealth of up-to-date information on the subject, much of it simple enough for beginning students to understand. This question is designed to get students researching sources other than their (poorly written) textbooks.

---

## Notes 6

Holes are difficult concepts to grasp for some students. An analogy I find helpful for explaining how the *absence* of an electron may be thought of as a particle is to refer to bubbles of air in water. When viewing bubbles of air in a clear, water-filled tube, it sure seems as though the bubbles are *discrete particles*, even though we know them to actually be *voids* where there is no water. And no one balks at the idea of assigning direction and speed to bubbles, even though they are really nothing rather than something!

The principle of energy bands sloping due to the presence of an electric field is vitally important for students to understand if they are to grasp the operation of a PN junction. An analogy that helps to visualize the electron and hole motion is to think of the two bands (conduction and valence) as two different pipes that can carry water. The upper pipe (the conduction band) is mostly empty, with only droplets of water running downhill. The bottom pipe (the valence band) is mostly full of water, with air bubbles running uphill.

One major point I wish to communicate here is that "hole flow" is not just a mirror-image of electron conduction. "Hole flow" is a fundamentally different mechanism of electron motion. Electrons are the only true charge carriers in any solid material, but "holes" are commonly referred to as "carriers" because they represent an easy-to-follow marker of valence electron motion. By referring to "holes" as entities unto themselves, it better distinguishes the two forms of electron motion (conduction-band versus valence-band).

Something you might want to point out to students, if they haven't already discovered it through their own research, is that there is no such thing as "hole flow" in metals. In metals, 100% of the conduction occurs through conduction-band electrons. This phenomenon of dual-mode electron flow only occurs when there is a band gap separating the valence and conduction bands. This is interesting to note, because many texts (even some high-level engineering textbooks!) refer to "conventional flow" current notation as "hole flow," even when the current exists in metal wires.

---

## Notes 7

The most important concept for students to grasp here is that the addition of impurities increases the number of available *charge carriers* in a semiconducting substance. What was essentially an insulator in its pure state may be made conductive to varying degrees by adding impurities.

---

## Notes 8

When doping silicon and germanium substrates, the materials used are classified as either *pentavalent* or *trivalent* substances. Ask your students which one of these terms refers to the greater valence number, and which refers to the lesser valence number.

---

## Notes 9

We speak of pure semiconductor materials, and of "doping" pieces of semiconductor material with just the right quantity and type(s) of dopants, but the reality is it is impossible to assure perfect quality control, and thus there *will* be other impurities in any semiconductor sample.

Ask your students to specifically identify the majority and minority charge carriers for "P" and "N" type extrinsic semiconductors. In each case, are they electrons, or holes?

---

## Notes 10

It is sometimes helpful to use analogies for illustrative purposes. An analogy for Fermi level is to imagine a pot of boiling water, where water molecules represent electrons and height represents energy level. Under ambient temperature conditions, there are many water molecules (electrons) leaving the liquid surface, and some that are returning to it. Cool the pot below the boiling point, however, and all the water molecules return to the liquid where the uppermost level represents the Fermi level in a substance.

---

Notes 11

This is one of those concepts I just couldn't understand when I had no comprehension of the quantum nature of electrons. In the "planetary" atomic model, there is no reason whatsoever for electrons to move from the N-piece to the P-piece unless there was an electric field pushing them in that direction. And conversely, once an electric field was created by the imbalance of electrons, the free-wheeling planetary theory would have predicted that the electrons move right back where they came from in order to neutralize the field.

Once you grasp the significance of quantized energy states, and the principle that particles do not "hold on" to unnecessary energy and therefore remain in high states when they could move down to a lower level, the concept becomes much clearer.

---

Notes 12

Ask your students what effect this change in depletion layer thickness has on overall conductivity through the PN junction. Under what conditions will the conductivity be greatest, and under what conditions will the conductivity be least?

---

Notes 13

Here it is very important that students understand the effects an electric field has on energy bands.

---

Notes 14

Here it is very important that students understand the effects an electric field has on energy bands.

---

Notes 15

Students will probably ask why there are a few holes shown in the N-type valence band, and why there are a few electrons in the P-type conduction band. Let them know that just because N-type materials are specifically designed to have conduction-band electrons does not mean they are completely devoid of valence-band holes, and visa-versa! What your students see here are *minority carriers*.

---

Notes 16

Ask your students how they would determine the size of resistor to use for this "diode test" circuit. Would be permissible to use any arbitrary value of resistor, or does the value matter significantly?

---

Notes 17

Review with your students what "minority carriers" are, and apply this concept to the PN junction. Trace the motions of these minority carriers, and compare them with the motions of majority carriers in a forward-biased PN junction.

---

Notes 18

Ask your students to sketch their own renditions of an exponential curve on the whiteboard for all to see. Don't just let them get away with parroting the answer: "It's an exponential curve."

---

Notes 19

I've seen too many students gain the false impression that silicon PN junctions *always* drop 0.7 volts, no matter what the conditions. This "fact" is emphasized so strongly in many textbooks that students usually don't think to ask when they measure a diode's forward voltage drop and find it to be considerably different than 0.7 volts! It is very important that students realize this figure is an approximation only, used for the sake of (greatly) simplifying junction semiconductor circuit analysis.

---

Notes 20

Diodes are quite temperature-sensitive, so this experiment will be very easy to conduct. You may not have ice available in your classroom, but that's okay. Your students should realize that experiments such as this are perfectly fair to perform at home, where they probably do have access to ice.

---

Notes 21

The answer to this question, if not found in a book, may be easily determined by direct experimentation. I recommend students verify information about electronics through experimentation whenever possible, and not rely solely on someone else's documentation.

---

Notes 22

Be sure to ask your students where they found the information on these different diode models!

Discuss with your students the importance of this rating, and why a person might choose the 1N4007 diode for an application rather than the 1N4001, for instance.

---

Notes 23

This simple yet ingenious circuit (not my design, lest you think I'm conceited) serves the purpose of illustrating diode rectification behavior, and provides a potential project for students to build and test.

---

Notes 24

There is a lot to discuss in this question. Not only does the concept of "curve tracing" merit attention, but the specific operation of this circuit is worthy of investigation as well. The reason I asked students to determine the "curve" for a resistor was to introduce them to the idea of graphing component current/voltage functions, and also to allow them to analyze the circuit with a more linear component under test than a semiconductor.

An important question to ask here is why channel Y of the oscilloscope must be inverted to obtain the graphs shown. What would the graphs look like if the channel were not inverted?

The challenge question may be rephrased as, "is the excitation voltage waveshape critical to obtaining a precise curve?" One way to demonstrate this is to use a function generator as the excitation voltage source (a transformer may be necessary to isolate the function generator ground from the oscilloscope ground!), and to try different waveshapes, watching the responses on the oscilloscope screen.

---

Notes 25

This question provides a good opportunity to review the direction of current through a battery when charging, versus when discharging. It also shows a way we can prevent the generator from "motoring" without having to use a reverse-current relay.

---

Notes 26

The answer to this question should not be much of a challenge to your students, although the follow-up question is a bit challenging. Ask your students what purpose the swamping resistors serve. What do we know about current through the diodes if one or more of them will fail due to overheating without the swamping resistors?

What value of resistor would your students recommend for this application? What factors influence their decision regarding the resistance value?

---

Notes 27

The answer to this question should not be much of a challenge to your students, although the follow-up question is a bit challenging. Ask your students what purpose the divider resistors serve. What do we know about voltage dropped across the diodes if one or more of them will fail without the divider resistors in place?

What value of resistor would your students recommend for this application? What factors influence their decision regarding the resistance value?

---

Notes 28

The purpose of this question is to get students to kinesthetically interact with the subject matter. It may seem silly to have students engage in a "show and tell" exercise, but I have found that activities such as this greatly help some students. For those learners who are kinesthetic in nature, it is a great help to actually *touch* real components while they're learning about their function. Of course, this question also provides an excellent opportunity for them to practice interpreting component markings, use a multimeter, access datasheets, etc.

---

Notes 29

Discuss this phenomenon with your students. Ask them whether they know of any other "polarized" (DC-only) devices. Ask them what they think would be necessary to make a DC-only device function on AC power.

---

Notes 30

Ask your students why the motor's torque pulsates instead of being steady as it would be when powered by a battery. Is this necessarily a bad thing? How does the motor's speed compare with being powered by a DC source of the same (RMS-equivalent) voltage?

---

Notes 31

Ask your students why this circuit is self-destructive. If it functions as a rectifier for powering the DC motor for a short period of time, then why doesn't it function that way for an indefinite period of time?

---

Notes 32

Although this circuit is not very complex, it reveals an application of diode rectification often overlooked: power control for non-polarized loads. Ask your students how the energy efficiency of a circuit like this compares to a rheostat (resistive) light dimming circuit.

---

Notes 33

This question not only introduces a type of full-wave rectifying circuit, but it also serves as a good review of transformer action and winding phase markings. I have omitted diagrams showing direction of currents in this circuit, partly because they may be ascertained by way of the load resistor's voltage polarity (shown in the answer), and partly because I'd rather not have to choose between giving an answer in conventional flow notation versus electron flow notation.

---

Notes 34

If this question is confusing to some students, take time to discuss the directions of all currents in the circuit through both halves of the AC cycle. Then, the answer should be apparent.

---

Notes 35

Realistic connection problems such as this are much easier to solve in the presence of a schematic diagram. If you have students who struggle with this question, make sure they take the time to draw a schematic *first*. Finding a schematic diagram of a full-wave bridge rectifier circuit to copy is no challenge at all. As a rule, I do not offer assistance to students with questions until they have at least taken this first step, because so often they end up answering their own questions in the process of drawing a schematic diagram!

---

Notes 36

Direct rectification of a grounded AC power source results in significant voltage being dropped between either DC output conductor and ground. Ask your students what kinds of problems might be caused by this effect. How about safety? Ask them if they think 58 volts presents a safety hazard.

In answer to the challenge question, what is needed here is some kind of electrical isolation. There is more than one answer to this problem, but definitely one solution that is more popular than the others.

---

Notes 37

The answer given here does not reveal everything. The student still must determine *why* grounding one of the rectifier circuit's output terminals results in a ground fault that blows the fuse. The observation of a half-wave signal with just the probe tip touching the circuit is the big hint in this question.

---

Notes 38

The meaning of these labels can be confusing, so be sure to discuss them thoroughly with your students. Have them tell you what "Phases," "Ways," and "Pulses" mean, using their own words.

---

Notes 39

Usually, rectifier circuits are thought of exclusively as intermediary steps between AC and DC in the context of an AC-DC power supply. They have other uses, though, as demonstrated by this interesting circuit!

It should be of no consequence if students have not yet studied transistors. In fact, it is a good thing to give them a very brief introduction to the function of a previously unknown component and then have them examine a circuit (the rest of which they should understand well) to ascertain an overall function. This is sometimes called the "Black Box" approach in engineering, and it is necessary when working around state-of-the-art electronic equipment, where you are practically guaranteed not to understand the inner workings of every subsystem and component.

---

Notes 40

The answer to this question should not be much of a challenge to your students, although the follow-up question is a bit challenging. Ask your students what purpose the swamping resistors serve in this circuit. What do we know about current through the diodes if one or more of them will fail due to overheating without the swamping resistors?

What value of resistor would your students recommend for this application? What factors influence their decision regarding the resistance value?

---

Notes 41

One factor not mentioned in the answer is circuit operating voltage. How do the operating voltages of a typical AC power system and a typical electronic circuit (radio, alarm clock, computer) compare? Ask your students what purpose a power supply has with regard to voltage.

Ask your students if the word "supply" is truly appropriate for this type of circuit. Does it really *supply* energy, or does it just convert energy from one form into another?

---

Notes 42

Many old television sets used such transformerless rectifier circuits to save money, but this meant the metal circuit chassis inside the plastic cover was energized rather than being at ground potential! Very dangerous for technicians to work on.

---

Notes 43

Many years ago, when I was first learning about power supplies, I tried to power an automotive radio with voltage from a battery charger. The battery charger was a simple power supply suitable for charging 12-volt automotive batteries, I reasoned, so what harm would there be in using it to power an automotive radio? After a few moments of LOUD humming from the radio speaker, my rhetorical question was answered by a puff of smoke from the radio, then silence.

Part of the problem was the output voltage of the battery charger, but a large part of the problem was the fact that the charger's output was *unfiltered* as well. For the same reasons my radio did not function properly on unfiltered, rectified AC, many electronic circuits will not function on it either.

---

Notes 44

As usual, what I'm looking for in an answer here is an *explanation* for what is happening. If a student simply tells you, "the vertical input is DC-coupled," press them for more detail. What does it mean for the input to be "DC-coupled," and why does this cause the line to disappear from the screen when we increase the vertical sensitivity? What alternative do we have to "DC coupling" on an oscilloscope?

One nice thing about oscilloscopes is that they cannot be damaged by "pegging" the display, as can analog multimeters. The same concept applies, though, and is useful in explaining to students why waveforms disappear from the screen when the vertical sensitivity is too great.

---

Notes 45

Ask your students what the term "loading" means in this context. Some of them may not comprehend the term accurately, and so it is good to review just to make sure.

More importantly, discuss with your students why the ripple is more severe under conditions of heavy loading. What, exactly, is happening in the circuit to produce this kind of waveform? If it is necessary for us to maintain a low amount of ripple under this heavy loading, what must we change in the power supply circuit?

---

Notes 46

The purpose of this question is to get students to look up the formula for calculating ripple voltage percentage. Notice how I did not simply ask them to regurgitate a formula; rather, I presented a realistic figure for them to interpret. When at all possible, try to format your questions in this sort of practical context!

---

Notes 47

Note that I did not simply say the ripple frequency is equal to line frequency for half-wave rectification and double the line frequency for full-wave. Such an answer is misleading, since it completely ignores polyphase AC rectification!

---

Notes 48

It is important for students to understand where this equation comes from. Ask your students to explain, step by step, the process of calculating output voltage for a simple power supply circuit. It is helpful in this process to calculate the voltage at each "stage" of the power supply (transformer primary, transformer secondary, etc.), as though we were building the circuit one component at a time.

Incidentally, the method of building a project (such as a power supply) in a step-by-step fashion rather than all at once, saves a lot of time and effort when things go wrong. The same "step-by-step" strategy works well for mathematical analysis, and other problem-solving tasks as well: try to analyze the circuit one "block" at a time instead of the whole thing at once.

---

Notes 49

The purpose of this question is to get students to look up the formula for calculating voltage regulation percentage. Notice how I did not simply ask them to regurgitate a formula; rather, I presented a realistic figure for them to interpret. When at all possible, try to format your questions in this sort of practical context!

---

Notes 50

A question such as this is best discussed while viewing the schematic diagram for a bridge rectifier. I recommend projecting an image of a bridge rectifier circuit on a whiteboard, then having students use dry-erase markers to "mark up" the schematic with arrows for current, voltage drop indications, etc. This way, mistakes can be corrected, or alternate cycles erased and re-drawn, without having to erase and re-draw the schematic diagram itself.

---

Notes 51

A common tendency for students is to troubleshoot using the "shotgun approach," which is to remove each component one-by-one and test it. This is a very time-intensive and inefficient method of troubleshooting. Instead, students need to develop diagnostic procedures not requiring removal of components from the circuit. At the very least, there should be some way we can narrow the range of possibilities using in-circuit tests prior to removing components.

---

Notes 52

Challenge your students with this question: is this the right kind of filter circuit (low pass, high pass, band pass, band stop) to be using, anyway? This question presents a good opportunity to review basic filter theory.

The follow-up question asks students to think carefully about the possible positive benefits of having a series resistor before the capacitor as shown in the student's original design. If your students are experiencing difficulty understanding why a resistor would ever be necessary, jog their memories with this formula:

$$i = C \frac{dv}{dt}$$

---

Notes 53

Before one can troubleshoot a malfunctioning circuit, one must know what voltages and currents are *supposed* to be in various portions of the circuit. This question, therefore, is a prelude to further troubleshooting questions.

---

Notes 54

Troubleshooting scenarios are always good for stimulating class discussion. Be sure to spend plenty of time in class with your students developing efficient and logical diagnostic procedures, as this will assist them greatly in their careers.



---

Notes 55

Troubleshooting scenarios are always good for stimulating class discussion. Be sure to spend plenty of time in class with your students developing efficient and logical diagnostic procedures, as this will assist them greatly in their careers.

Students may be puzzled by the presence of DC voltage between TP7 and TP8, and also between TP9 and TP10 (1.1 volts), given that there is less than that amount of AC voltage at the rectifier's input. However, this is a common phenomenon with electrolytic capacitors, to "recover" a small voltage after having been discharged.

---

Notes 56

Troubleshooting scenarios are always good for stimulating class discussion. Be sure to spend plenty of time in class with your students developing efficient and logical diagnostic procedures, as this will assist them greatly in their careers.

---

Notes 57

In a filtered DC power supply, the only time current is drawn from the rectifier is when the filter capacitor charges. Thus, the only time you see input current above and beyond the magnetizing current waveform is when the capacitor voltage requires charging.

Note that although the (sinusoidal) magnetizing current waveform is  $90^\circ$  out of phase with the voltage waveform, the input current transients are precisely in-phase with the current transients on the transformer's secondary winding. This reviews an important principle of transformers: that whatever primary current is the result of secondary winding load is in-phase with that secondary load current. In this regard, a transformer does not act as a reactive device, but a direct power-coupling device.

Note also that after the initial surge (rising pulse edge) of current, the input current waveform follows a different curve from the voltage waveform, because  $i = C \frac{dv}{dt}$  for a capacitor.

In case you haven't guessed by now, there is a lot of stuff happening in this circuit! I would consider this question to be "advanced" for most introductory-level courses, and may be skipped at your discretion.

---

Notes 58

Ask your students how they determined the identity of this filter. Are they strictly memorizing filter configurations, or do they have a technique for determining what type of filter circuit it is based on basic electrical principles (reactance of components to different frequencies)? Remind them that rote memorization is a very poor form of learning!

---

Notes 59

If students experience difficulty calculating the necessary PIV rating for this circuit's diode, ask them to analyze the peak output from the transformer's secondary winding *for each half-cycle of the AC waveform*, noting the voltage drops across all circuit components. Once a full-cycle voltage analysis is performed for all circuit components, the necessary diode rating should become obvious.

Though it may not be obvious at first reading, this question may actually serve as a lead-in for discussing voltage multiplier circuits. The fact that the diode experiences a reverse voltage *twice* that of the peak AC voltage is something we may exploit!

Another reliability factor most students won't recognize in this circuit is the "inrush" current experienced by the diode every time the circuit is powered up and the capacitor recharges. Certainly, the diode was not properly rated for the reverse voltage it was being subjected to, but this might not be the only form of abuse! If time permits, discuss this possibility as well.

---

Notes 60

Students need not provide details of voltage regulation, but merely show how AC from a center-tapped transformer winding may be rectified into two distinct DC outputs with a common "ground" connection.

---

Notes 61

Ask your students if they happened to research any datasheets for Schottky diodes, and if they have parameters to compare against typical PN junction rectifying diodes such as the 1N400x series.

---

Notes 62

Ask your students to explain why the applications of Schottky diodes are well suited for these diodes' unique capabilities. What is it about the typical applications that make use of these diodes' fast reverse-recovery times and/or low forward voltage drop?

Note to your students that the schematic symbol for a Schottky diode is easily confused with the schematic symbol for a *zener* diode. Pay close attention to the symbol!

---

Notes 63

The practical application of this phenomenon should be obvious, and it is very commonplace in modern electronic equipment. Discuss with your students the energy-efficiency of this light emission as compared to an incandescent lamp.

---

Notes 64

Ask your students to identify some common LED materials and colors, and of course cite their sources as they do. The challenge question may be readily answered through experimentation with different LED colors, although a physics-based explanation will take some additional research. This kind of experiment is very easy to conduct in class, together.

If time permits, you might wish to mention Albert Einstein's contribution to this aspect of physics: his formulation for the energy carried by a photon (a *quantum*) of light:

$$E = hf$$

Where,

$E$  = Energy carried by photon, in Joules

$h$  = Planck's constant,  $6.63 \times 10^{-34}$  J·s

$f$  = Frequency of light, in Hertz ( $\frac{1}{s}$ )

Typical frequencies for visible light colors range from  $4 \times 10^{14}$  Hz for red, to  $7.5 \times 10^{14}$  Hz for violet.

---

Notes 65

Be sure to ask students where they obtained their information, and what some of the forward voltage drops are for different color LEDs.

---

Notes 66

The follow-up question is a very practical one, for it is seldom that you have the exact components on-hand to match the requirements of a circuit you are building. It is important to understand which way is safer to err (too large or too small) when doing "as-built" design work.

---

Notes 67

This question reinforces students' understanding of the mathematical terms *direct* and *inverse*, as well as review basic PN junction theory and capacitor theory.

---

Notes 68

Ask your students to identify the region of the curve described by Shockley's diode equation. The exponential form of that equation really only models one definite portion of the curve!

---

Notes 69

Ask students what zener diodes would likely be used for. Why would we need or desire a device with a stable breakdown voltage?

---

Notes 70

The direction of rheostat adjustment should be obvious, as is the fact that the generator's voltage must be at least as high as the intended (target) load voltage. However, it may not be obvious to all that the generator's voltage cannot merely be equal to the intended load voltage.

To illustrate the necessity of this, ask your students how the system would work if the generator's output voltage was exactly equal to the intended load voltage. Emphasize the fact that the generator is not perfect: it has its own internal resistance, the value of which cannot be changed by you. What position would the rheostat have to be in, under these conditions, in order to maintain target voltage at the load? Could the target voltage be maintained at all?

---

Notes 71

The direction of rheostat adjustment should be obvious, as is the fact that the generator's voltage must be at least as high as the intended (target) load voltage. However, it may not be obvious to all that the generator's voltage cannot merely be equal to the intended load voltage.

To illustrate the necessity of this, ask your students how the system would work if the generator's output voltage was exactly equal to the intended load voltage. Emphasize the fact that the generator is not perfect: it has its own internal resistance, the value of which cannot be changed by you. What position would the rheostat have to be in, under these conditions, in order to maintain target voltage at the load? Could the target voltage be maintained at all?

A helpful analogy for students is that of a car with an automatic transmission, with its speed being controlled by the brake pedal while the accelerator pedal is maintained at a constant position. This is not the most energy-efficient method of speed control, but it will work within certain limits!

---

Notes 72

Ask your students to describe how energy-efficient they think this circuit is. Do they suspect it would be more suitable for low-current applications or high-current applications?

---

Notes 73

This exercise in current calculation is supposed to get students to realize the inverse relationship between load current and zener current: that the zener diode regulates voltage by acting as a parasitic load of varying proportion. Simply put, the diode loads down the circuit as much as needed to maintain a stable voltage at the load terminals.

It should be noted that the calculated answers shown here will *not* precisely match a real zener diode circuit, due to the fact that zener diodes tend to gradually taper off in current as the applied voltage nears the zener voltage rating rather than current sharply dropping to zero as a simpler model would predict.

The follow-up question is very important. All zener diode regulator circuits have a minimum load resistance value that must be adhered to, lest the output voltage droop below the regulation point. Discuss with your students how the zener diode's "loading" behavior explains the need for a certain minimum load resistance value.

---

Notes 74

This exercise in current calculation is supposed to get students to realize the inverse relationship between input voltage and zener current: that the zener diode regulates voltage by acting as a parasitic load of varying proportion. Simply put, the diode loads down the circuit as much as needed to maintain a stable voltage at the load terminals.

It should be noted that the calculated answers shown here will *not* precisely match a real zener diode circuit, due to the fact that zener diodes tend to gradually taper off in current as the applied voltage nears the zener voltage rating rather than current sharply dropping to zero as a simpler model would predict.

The follow-up question is very important. All zener diode regulator circuits have a minimum input voltage value that must be adhered to, lest the output voltage droop below the regulation point. Discuss with your students how the zener diode's "loading" behavior explains the need for a certain minimum source voltage.

---

Notes 75

I have actually done this before in home-made circuitry. Voltage regulation isn't that good (especially the temperature dependence), but it is better than no regulation at all!

---

Notes 76

For those students struggling with the "greater than"/"less than" issue, suggest to them that they imagine the load resistance assuming extreme values: first 0 ohms, and then infinite ohms. After they do this, ask them to determine under which of these extreme conditions is the load voltage regulation still maintained.

Performing "thought experiments" with extreme component values is a highly effective problem-solving technique for many applications, and is one you should stress to your students often.

It should be noted that the calculated answer shown here will *not* precisely match a real zener diode circuit, due to the fact that zener diodes tend to gradually taper off in current as the applied voltage nears the zener voltage rating rather than current sharply dropping to zero as a simpler model would predict.

---

Notes 77

Regular "rectifying" diodes also have temperature coefficients. Ask your students to identify whether the temperature coefficient for a rectifying diode is typically positive or negative, and what this actually means. It is very easy to experimentally verify this, so you may want to ask your students to demonstrate how to determine the sign of a rectifying diode's temperature coefficient as a prelude to reviewing the experimental portion of the original question.

Ask your students to identify the typical voltage values associated with both types of breakdown effect. This will quickly reveal which students did their research for this question, as opposed to those who merely read the answer given here!

---

Notes 78

Some students may become confused by the word "complementary" as it is used in the answer. Ask all your students to explain what this word means, in the context of two temperature coefficients and increased stability.

---

Notes 79

I usually do not ask "trick" questions such as this, but occasionally they work really well to get the point across.

---

Notes 80

Ask your students to relate a diode's zener impedance to the slope of its characteristic curve.

---

Notes 81

The scenario shown is not academic – it is what happens when an electric field is applied to water. The dissociated ions move in opposite directions, liberating hydrogen gas at the negative electrode and oxygen gas at the positive.

---

Notes 82

This question breaches one of the more contentious subjects in electricity/electronics: which way do we denote the direction of current? While there is no debate as to which direction *electrons* move through a metal conductor carrying current, there are two different conventions for denoting current travel, one of which goes in the direction of electrons and the other which goes against the direction of electrons. The reason for having these two disparate conventions is embedded in the history of electrical science, and what your students find in their research will likely fuel an interesting conversation.

---

Notes 83

In case anyone asks, the little circles with the letter "e" inside are supposed to represent electrons. Kind of silly, I know, but I was looking for some way of clearly distinguishing one direction from the other without just relying on the text labels.

---

Notes 84

Other examples exist, so do not accept the given answer as the only answer!

Note: some students may suggest holes in semiconductors as an example of positive charge-carriers. This is technically not true, though. A "hole" does not exist as a real particle of matter. It is an abstraction, used by solid-state physicists and engineers to differentiate conduction-band electron motion ("electrons") from valence-band electron motion ("holes").

---

Notes 85

There are plenty of information sources for students to research on this topic. Ask them where they found their facts!

---

Notes 86

Your students can see how confusing this can be, with arrowheads sometimes representing direction of current and sometimes not. In a semiconductor device, an arrowhead simply represents a PN junction, with the direction of that arrowhead representing how conventional flow *would go if* that PN junction were forward-biased.

Then, of course, we have the symbol for a current source, whose arrow *always* points in the direction of conventional flow.

It should become apparent that conventional flow is the easiest approach when working with semiconductor devices. There are many people (technicians, especially) who successfully apply electron flow to the analysis of semiconductor devices, but they have to train themselves to think "against the arrow." This adds one more level of confusion to an already (potentially) confusing topic, which is why I personally choose to teach conventional flow when first exposing students to semiconductor devices.

Any way you approach this subject, it is a sad state of affairs!

---

Notes 87

It is important to remember that there is only one convention for using "+" and "-" symbols to designate the polarity of a voltage drop (thankfully!).

---

Notes 88

A good strategy might be to use a pencil and *lightly* draw the arrows in the direction of conventional flow, then over-draw those arrows in the reverse direction using more hand pressure (making a darker line).

It should go without saying that this technique works just as well for the person who is more comfortable with electron flow notation, but must switch to conventional flow for some reason.

---

Notes 89

The answer given provides a clue as to why electron flow notation is still popular among technicians and the institutions that train them. There is a legacy of electron-flow-based instruction originating from the days when vacuum tubes were the predominant active component in electronic circuits. If you are teaching the operation of these devices in the simplest terms, so that non-engineers can understand them, it would make the most sense to standardize on a notation for current that follows the actual electrons. Electrical engineers, on the other hand, established their own convention for designating direction of current before the electron was even discovered, which is why that branch of electrical science still denotes the direction of current opposite the direction of electron motion.

---

Notes 90

The only clues as to notation are the arrows. Students may not be at the point where they can recognize the proper directions of current for the non-arrowed component terminals, but at least they should be able to compare the current arrows against the component symbol arrows and see whether there is agreement (conventional flow) or disagreement (electron flow).

---

Notes 91

Use a variable-voltage, regulated power supply to supply any amount of DC voltage below 30 volts. Specify standard resistor values, all between 1 k $\Omega$  and 100 k $\Omega$  (1k5, 2k2, 2k7, 3k3, 4k7, 5k1, 6k8, 10k, 22k, 33k, 39k 47k, 68k, etc.). I recommend using one of the 1N400X series of rectifying diodes for their low cost and ruggedness.

An extension of this exercise is to incorporate troubleshooting questions. Whether using this exercise as a performance assessment or simply as a concept-building lab, you might want to follow up your students' results by asking them to predict the consequences of certain circuit faults.

I recommend using 1N400X series rectifying diodes for all rectifier circuit designs. Make sure that the resistance value you specify for your load is not so low that the resistor's power dissipation is exceeded.

Watch out for harmonics in the power line voltage creating problems with RMS/peak voltage relationships. If this is a problem, try using a ferroresonant transformer to filter out some of the harmonic content. *Do not* try to use a sine-wave signal generator as an alternate source of AC power, because most signal generators have internal impedances that are much too high for such a task.

It is difficult to precisely calculate the DC load voltage from a rectifier circuit such as this when the transformer secondary voltage is relatively low. The diodes' forward voltage drop essentially distorts the rectified waveform so that it is not quite the same as what you would expect a full-wave rectified waveform to be:

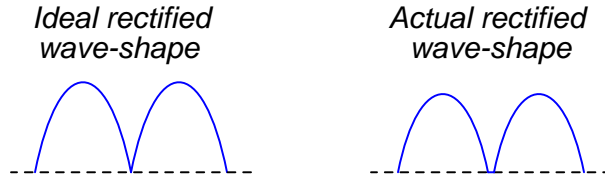

Accurate calculation of the actual rectified wave-shape's average voltage value requires integration of the half-sine peak over a period less than  $\pi$  radians, which may very well be beyond the capabilities of your students. This is why I request approximations only on this parameter.

One approximation that works fairly well is to take the AC RMS voltage (in this case, half of the secondary winding's output, since this is a center-tap design), convert it to *average* voltage (multiply by 0.9), and then subtract the forward junction voltage lost by the diode (0.7 volts typical for silicon).

An extension of this exercise is to incorporate troubleshooting questions. Whether using this exercise as a performance assessment or simply as a concept-building lab, you might want to follow up your students' results by asking them to predict the consequences of certain circuit faults.

I recommend using 1N400X series rectifying diodes for all rectifier circuit designs. Make sure that the resistance value you specify for your load is not so low that the resistor's power dissipation is exceeded.

Watch out for harmonics in the power line voltage creating problems with RMS/peak voltage relationships. If this is a problem, try using a ferroresonant transformer to filter out some of the harmonic content. *Do not* try to use a sine-wave signal generator as an alternate source of AC power, because most signal generators have internal impedances that are much too high for such a task.

It is difficult to precisely calculate the DC load voltage from a rectifier circuit such as this when the transformer secondary voltage is relatively low. The diodes' forward voltage drop essentially distorts the rectified waveform so that it is not quite the same as what you would expect a full-wave rectified waveform to be:

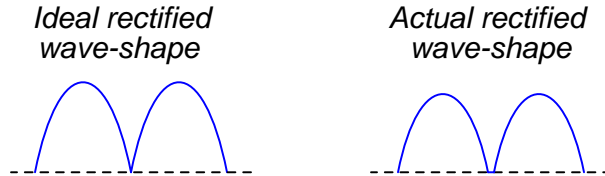

Accurate calculation of the actual rectified wave-shape's average voltage value requires integration of the half-sine peak over a period less than  $\pi$  radians, which may very well be beyond the capabilities of your students. This is why I request approximations only on this parameter.

One approximation that works fairly well is to take the AC RMS voltage, convert it to *average* voltage (multiply by 0.9), and then subtract the total forward junction voltage lost by the diode (0.7 volts per diode typical for silicon, for a total of 1.4 volts).

An extension of this exercise is to incorporate troubleshooting questions. Whether using this exercise as a performance assessment or simply as a concept-building lab, you might want to follow up your students' results by asking them to predict the consequences of certain circuit faults.



---

## Notes 94

Use a variable-voltage, regulated power supply to supply any amount of DC voltage below 30 volts. Specify standard load resistor values, all between 1 k $\Omega$  and 100 k $\Omega$  (1k5, 2k2, 2k7, 3k3, 4k7, 5k1, 6k8, 10k, 22k, 33k, 39k, 47k, 68k, etc.), and let the students determine the proper resistance values for their series dropping resistors.

I recommend specifying a series resistor value ( $R_{series}$ ) high enough that there will be little danger in damaging the zener diode due to excessive supply voltage, but also low enough so that the normal operating current of the zener diode is great enough for it to drop its rated voltage. If  $R_{series}$  is too large, the zener diode's current will be too small, resulting in lower than expected voltage drop and poorer regulation (operating near the flatter end of the characteristic curve).

Values I have used with success are as follows:

- $R_{series} = 1 \text{ k}\Omega$
- $R_{load} = 10 \text{ k}\Omega$
- $V_{zener} = 5.1 \text{ volts}$  (diode part number 1N4733)
- $V_{supply} = 12 \text{ volts}$

Measuring the minimum supply voltage is a difficult thing to do, because students must look for a point where the output voltage begins to directly follow the input voltage (going down) instead of holding relatively stable. One interesting way to measure the rate of output voltage change is to set a DMM on the AC voltage setting, then use that to measure  $V_{load}$  as  $V_{supply}$  is decreased. While turning the voltage adjustment knob on  $V_{supply}$  at a steady rate, students will look for an increase in AC voltage (a greater rate of change) at  $V_{load}$ . Essentially, what students are looking for is the point where  $\frac{dV_{load}}{dV_{supply}}$  begins to increase.

An extension of this exercise is to incorporate troubleshooting questions. Whether using this exercise as a performance assessment or simply as a concept-building lab, you might want to follow up your students' results by asking them to predict the consequences of certain circuit faults.

---

## Notes 95

Use a variable-voltage, regulated power supply to supply any amount of DC voltage below 30 volts. Have students calculate the necessary current-limiting resistor for their LEDs based on measured values of  $V_{forward}$  for the LED (using a multimeter with a "diode-check" function). Let students research the typical forward current for their LED from an appropriate datasheet. Any LED should suffice for this activity.

An extension of this exercise is to incorporate troubleshooting questions. Whether using this exercise as a performance assessment or simply as a concept-building lab, you might want to follow up your students' results by asking them to predict the consequences of certain circuit faults.

---

## Notes 96

The purpose of this assessment rubric is to act as a sort of "contract" between you (the instructor) and your student. This way, the expectations are all clearly known in advance, which goes a long way toward disarming problems later when it is time to grade.

---

## Notes 97

The purpose of this question is to approach the domain of circuit troubleshooting from a perspective of knowing what the fault is, rather than only knowing what the symptoms are. Although this is not necessarily a realistic perspective, it helps students build the foundational knowledge necessary to diagnose a faulted circuit from empirical data. Questions such as this should be followed (eventually) by other questions asking students to identify likely faults based on measurements.

---

Notes 98

The purpose of this question is to approach the domain of circuit troubleshooting from a perspective of knowing what the fault is, rather than only knowing what the symptoms are. Although this is not necessarily a realistic perspective, it helps students build the foundational knowledge necessary to diagnose a faulted circuit from empirical data. Questions such as this should be followed (eventually) by other questions asking students to identify likely faults based on measurements.

---

Notes 99

The purpose of this question is to approach the domain of circuit troubleshooting from a perspective of knowing what the fault is, rather than only knowing what the symptoms are. Although this is not necessarily a realistic perspective, it helps students build the foundational knowledge necessary to diagnose a faulted circuit from empirical data. Questions such as this should be followed (eventually) by other questions asking students to identify likely faults based on measurements.

---

Notes 100

The purpose of this question is to approach the domain of circuit troubleshooting from a perspective of knowing what the fault is, rather than only knowing what the symptoms are. Although this is not necessarily a realistic perspective, it helps students build the foundational knowledge necessary to diagnose a faulted circuit from empirical data. Questions such as this should be followed (eventually) by other questions asking students to identify likely faults based on measurements.

---

Notes 101

The purpose of this question is to approach the domain of circuit troubleshooting from a perspective of knowing what the fault is, rather than only knowing what the symptoms are. Although this is not necessarily a realistic perspective, it helps students build the foundational knowledge necessary to diagnose a faulted circuit from empirical data. Questions such as this should be followed (eventually) by other questions asking students to identify likely faults based on measurements.

---

Notes 102

The purpose of this question is to approach the domain of circuit troubleshooting from a perspective of knowing what the fault is, rather than only knowing what the symptoms are. Although this is not necessarily a realistic perspective, it helps students build the foundational knowledge necessary to diagnose a faulted circuit from empirical data. Questions such as this should be followed (eventually) by other questions asking students to identify likely faults based on measurements.

---

Notes 103

Troubleshooting scenarios are always good for stimulating class discussion. Be sure to spend plenty of time in class with your students developing efficient and logical diagnostic procedures, as this will assist them greatly in their careers.

Remind your students that test instrument readings are not the only viable source of diagnostic data! Burnt electronic components usually produce a strong and easily-recognized odor, always indicative of overheating. It is important to keep in mind that often the burnt component is *not* the original source of trouble, but may be a casualty of some other component fault.

---

Notes 104

The purpose of this question is to approach the domain of circuit troubleshooting from a perspective of knowing what the fault is, rather than only knowing what the symptoms are. Although this is not necessarily a realistic perspective, it helps students build the foundational knowledge necessary to diagnose a faulted circuit from empirical data. Questions such as this should be followed (eventually) by other questions asking students to identify likely faults based on measurements.

---

Notes 105

The purpose of this question is to approach the domain of circuit troubleshooting from a perspective of knowing what the fault is, rather than only knowing what the symptoms are. Although this is not necessarily a realistic perspective, it helps students build the foundational knowledge necessary to diagnose a faulted circuit from empirical data. Questions such as this should be followed (eventually) by other questions asking students to identify likely faults based on measurements.

---

Notes 106

The purpose of this question is to approach the domain of circuit troubleshooting from a perspective of knowing what the fault is, rather than only knowing what the symptoms are. Although this is not necessarily a realistic perspective, it helps students build the foundational knowledge necessary to diagnose a faulted circuit from empirical data. Questions such as this should be followed (eventually) by other questions asking students to identify likely faults based on measurements.

---

Notes 107

Before you discuss "RMS" values with your students, it is important to cover the basic idea of how to assign fixed values to quantities that change over time. Since AC waveforms are *cyclic* (repeating), this is not as difficult to do as one might think.

---

Notes 108

There are many analogies to explain this discrepancy between the two "50 volt" sources. One is to compare the physical effort of a person pushing with a constant force of 50 pounds, versus someone who pushes intermittently with only a *peak* force of 50 pounds.

---

Notes 109

Ask your students, "how much *peak* voltage is the AC power source outputting? More or less than 120 volts?"

If one of your students claims to have calculated the peak voltage as 169.7 volts, ask them how they arrived at that answer. Then ask if that answer depends on the shape of the waveform (it does!). Note that the question did not specify a "sinusoidal" wave shape. Realistically, an adjustable-voltage AC power supply of substantial power output will likely be sinusoidal, being powered from utility AC power, but it *could* be a different wave-shape, depending on the nature of the source!

---

Notes 110

Students must properly interpret the oscilloscope's display, then correctly convert to RMS units, in order to obtain the correct answer for this question.

---

Notes 111

This question is not only good for introducing basic oscilloscope principles, but it is also excellent for review of AC waveform measurements.

---

Notes 112

Transformer winding calculations are simply an exercise in mathematical ratios. If your students are not strong in their ratio skills, this question provides an application to sharpen them!

---

Notes 113

Transformer winding calculations are simply an exercise in mathematical ratios. If your students are not strong in their ratio skills, this question provides an application to sharpen them!

---

---

Notes 114

Transformer winding calculations are simply an exercise in mathematical ratios. If your students are not strong in their ratio skills, this question provides an application to sharpen them!

---

Notes 115

Most transformer problems are nothing more than ratios, but some students find ratios difficult to handle. Questions such as this are great for having students come up to the board in the front of the classroom and demonstrating how they obtained the results.

---

Notes 116

Most transformer problems are nothing more than ratios, but some students find ratios difficult to handle. Questions such as this are great for having students come up to the board in the front of the classroom and demonstrating how they obtained the results.

---

Notes 117

Just a simple definition here, nothing more. This is easily referenced in any introductory textbook.

---

Notes 118

A couple of technical terms are used in this question (doping, extrinsic). Be sure to ask your students what they mean, if only for the sake of review. Also, ask your students to relate their answer in terms of charge carriers.

---

Notes 119

Nothing much to comment on here, as this sort of question may be easily answered through research of any introductory textbook.

---

Notes 120

Nothing much to comment on here, as this sort of question may be easily answered through research of any introductory textbook.

---

Notes 121

The answer to this question is a short review on temperature coefficients of resistance ( $\alpha$ ), for those students who may not recall the subject from their DC circuit studies. As always, though, the most important point of this question is *why* conductivity increases for semiconductors. Ask your students to relate their answer to the concept of *charge carriers* in semiconducting substances.

An interesting bit of trivia you could mention to your students is that glass – normally an excellent insulator of electricity – may be made electrically conductive by heating. Glass must be heated until it is red-hot before it becomes really conductive, so it is not an easy phenomenon to demonstrate. I found this gem of an experiment in an old book: Demonstration Experiments in Physics, first edition (fourth impression), copyright 1938, by Richard Manliffe Sutton, Ph.D.

---

Notes 122

Note how much the Fermi level is affected by the addition of dopants to an otherwise pure semiconducting material. Understanding this effect is critical to the understanding of PN semiconductor junctions.

---

Notes 123

This tidbit of semiconductor history was found in Electronics for Scientists and Engineers, by R. Ralph Benedict, on pages 113 and 114. Like many other engineering textbooks of the 1950's and 1960's, this publication is at once a treasure trove of technical information and a model of clarity. I only wish the technician-level textbooks of today could be so lucid as the engineering-level textbooks of decades ago. As you might have guessed, I enjoy haunting used book stores in search of vintage engineering texts!

---

Notes 124

Students should know that both "N" and "P" type semiconductors are electrically conductive. So, when a depletion region forms in the contact zone between two differing semiconductor types, the conductivity from end-to-end must be affected. Ask your students what this effect is, and what factors may influence it.

---

Notes 125

Nothing much to comment on here!

---

Notes 126

Nothing much to comment on here!

---

Notes 127

Of course, students will have to research the difference between degrees Kelvin and degrees Celsius to successfully calculate the thermal voltage for the junction. They will also have to figure out how to substitute this figure in place of  $q$ ,  $k$ , and  $T$  in the original equation. The latter step will be difficult for students not strong in algebra skills.

For those students, I would suggest posing the following question to get them thinking properly about algebraic substitution. Suppose we had the formula  $y = x^{\frac{a}{c}}$ , and we knew that  $\frac{b}{c}$  could be written as  $m$ . How would we substitute  $m$  into the original equation? Answer:  $y = x^{\frac{am}{d}}$ .

---

Notes 128

The algebraic technique used to solve for  $K$  is very useful for certain types of problems.

Discuss the follow-up question with your students. It is important in the realm of technical mathematics to have a good sense of the relative values of equation terms, so that one may "safely" eliminate terms as a simplifying technique without incurring significant errors. In the Shockley diode equation it is easy to show that the exponential term is *enormous* compared to 1 for the values of  $V_{diode}$  shown in the table (assuming a typical value for thermal voltage), and so the "- 1" part is very safe to eliminate.

Also discuss the idea of verifying the calculated values of  $K$  and  $I_S$  with your students, to help them cultivate a scientifically critical point of view in their study of electronics.

Incidentally, the data in this table came from a real experiment, set up exactly as shown by the schematic diagram in the question. Care was taken to avoid diode heating by turning the potentiometer to maximum resistance between readings.

---

Notes 129

This question is a good review of capacitor theory, and also an opportunity to introduce a special kind of diode: the *varactor*.

---

Notes 130

Discuss the nature of heat with your students: that a differential temperature ( $\Delta T$ ) is required for transfer of heat through a medium such as a solid. Compare this phenomenon with differences of electrical potential ( $E$ ) and electric current ( $I$ ). How do we express an electrical conductor's ability to carry a moving charge under the influence of a potential difference?

Ask your students what difference it makes whether a semiconductor component has a high or a low thermal resistance. What is ideal for a semiconductor device, a high thermal resistance or a low thermal resistance? Why?

---

Notes 131

Discuss with your students why temperature is such a critical factor in semiconductor component operation. What happens to a semiconductor junction when it is heated? What may happen if it is heated too much?

---

Notes 132

Characteristic curves are not the easiest concept for some students to grasp, but they are incredibly informative. Not only can they illustrate the electrical behavior of a nonlinear device, but they can also be used to diagnose otherwise hard-to-measure faults. Letting students figure out what shorted and open curves look like is a good way to open their minds to this diagnostic tool, and to the nature of characteristic curves in general.

Although it is far from obvious, one of the oscilloscope channels will have to be "inverted" in order for the characteristic curve to appear in the correct quadrant(s) of the display. Most dual-trace oscilloscopes have a "channel invert" function that works well for this purpose. If engaging the channel invert function on the oscilloscope flips the wrong axis, you may reverse the connections of the test device to the curve tracer circuit, flipping both axes simultaneously. Between reversing device connections and reversing one channel of the oscilloscope, you can get the curve to plot any way you want it to!

---

Notes 133

Modeling nonlinear semiconductor components in terms of linear, idealized passive components is a time-honored "trick" used to simplify circuit analysis. Like all "tricks" and analogies, this one has definite limitations. The follow-up question's hint practically gives away examples of where such a model could be misleading!

---

Notes 134

Ask your students to describe what the "ideal"  $t_{rr}$  and  $C_j$  values would be for a diode with unlimited rectification bandwidth.

---

Notes 135

There is quite a bit of detail that could be added to the account given in the answer. Ask your students to supply some of this detail! There are many resources for learning how photovoltaic cells work, so your students should have no trouble finding the information on their own.

---

Notes 136

The purpose of this question is to cause students to think about what a characteristic curve means, in the context of diode comparisons. The breakdown voltage of a zener diode is typically so low compared to that of a normal rectifying diode that this region may be easily shown on the curve tracer screen.

---

Notes 137

Some students may suggest to use normal diodes backwards, exploiting the reverse-breakdown phenomenon common to all PN junctions. Whether or not this suggestion is made, ask your students why it would not be a practical solution in this case.

---

Notes 138

The gas discharge lamp's transfer function may be confusing to analyze at first, but it makes sense once students recall the principle of gas ionization with increasing voltage. Ask them to explain what the significance of each graph's vertical portions is, in the context of voltage regulation.

---

Notes 139

The follow-up question is fairly important here, as students need to realize the limitations of zener-based voltage regulators. Most importantly, are they able to calculate the exact current limit of a zener-based voltage regulator – the point at which it stops regulating?

It should be noted that the calculated answers shown here will *not* precisely match a real zener diode circuit, due to the fact that zener diodes tend to gradually taper off in current as the applied voltage nears the zener voltage rating rather than current sharply dropping to zero as a simpler model would predict.

---

Notes 140

Some students may protest at the first Thévenin equivalent circuit (with a 0 ohm series resistance), because this would be a *perfect* voltage source. In reality, there would be a very small series resistance accounting for the slight voltage "sag" experienced under changing loads within the regulation range, but this is difficult to calculate.

---

Notes 141

Challenge your students to show you a datasheet for one of these devices!

---

Notes 142

This question provides an excellent opportunity to review inductor theory, particularly the direction of current and the polarity of voltage for an inductor when charging versus when discharging. Analysis of this circuit will be made easier by drawing a schematic diagram.

---

Notes 143

A very important point to ask your students is how they figured out the meter's indication. What circuit analysis technique did they use, and why?

Emphasize solving this problem without using a calculator to do the math. Are your students able to determine the result by estimation alone? Does the input resistance factor into the calculation significantly?

---

Notes 144

Discuss both the nature of the problem, and of the solution, with your students. Why does the proposed solution work to eliminate power failure in the event of a short-circuit internal to one of the power sources?

The result of this derivation is important in the analysis of certain transistor amplifiers, where the dynamic resistance of the base-emitter PN junction is significant to bias and gain approximations. I show the solution steps for you here because it is a neat application of differentiation (and substitution) to solve a real-world problem:

$$I = I_S(e^{40V} - 1)$$

$$\frac{dI}{dV} = I_S(40e^{40V} - 0)$$

$$\frac{dI}{dV} = 40I_S e^{40V}$$

Now, we manipulate the original equation to obtain a definition for  $I_S e^{40V}$  in terms of current, for the sake of substitution:

$$I = I_S(e^{40V} - 1)$$

$$I = I_S e^{40V} - I_S$$

$$I + I_S = I_S e^{40V}$$

Substituting this expression into the derivative:

$$\frac{dI}{dV} = 40(I + I_S)$$

Reciprocating to get voltage over current (the proper form for resistance):

$$\frac{dV}{dI} = \frac{0.025}{I + I_S}$$

Now we may get rid of the saturation current term, because it is negligibly small:

$$\frac{dV}{dI} \approx \frac{0.025}{I}$$

$$r \approx \frac{25 \text{ mV}}{I}$$

The constant of 25 millivolts is not set in stone, by any means. Its value varies with temperature, and is sometimes given as 26 millivolts or even 30 millivolts.