

Basic ammeter use

This worksheet and all related files are licensed under the Creative Commons Attribution License, version 1.0. To view a copy of this license, visit <http://creativecommons.org/licenses/by/1.0/>, or send a letter to Creative Commons, 559 Nathan Abbott Way, Stanford, California 94305, USA. The terms and conditions of this license allow for free copying, distribution, and/or modification of all licensed works by the general public.

Resources and methods for learning about these subjects (list a few here, in preparation for your research):

Questions

Question 1

Show how this ammeter would be connected to the light bulb circuit to measure the circuit's electric current:

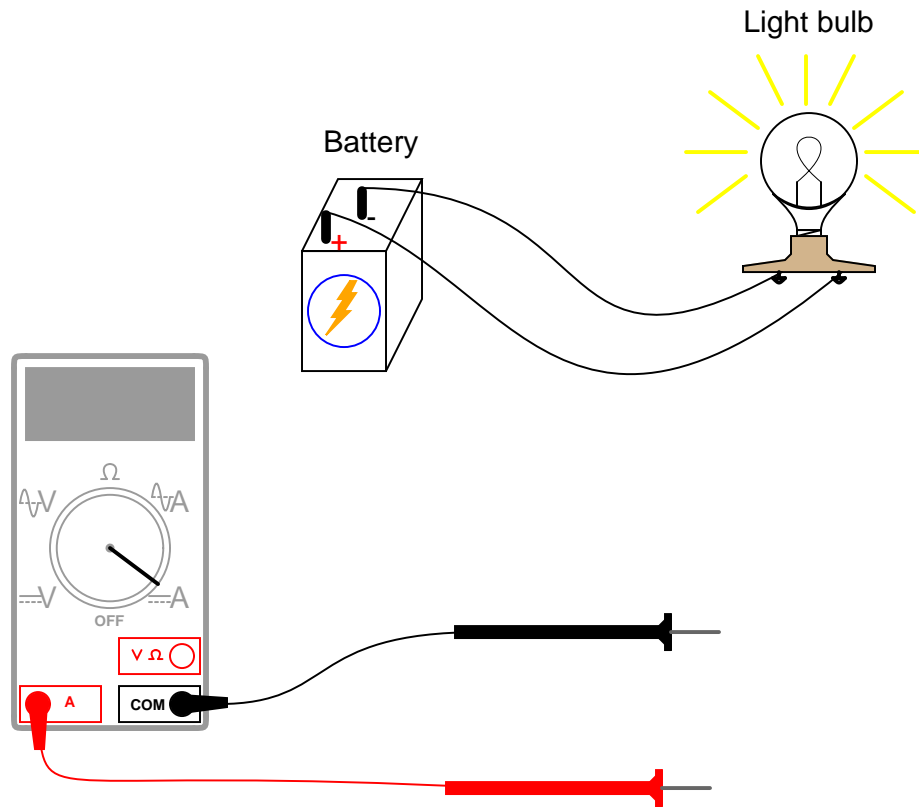

Also, draw a schematic diagram of this same circuit (with the ammeter connected).
[file 01699](#)

Question 2

If we were to connect an ammeter directly to an ohmmeter, what would you expect to see the ohmmeter register, for resistance between its test leads?

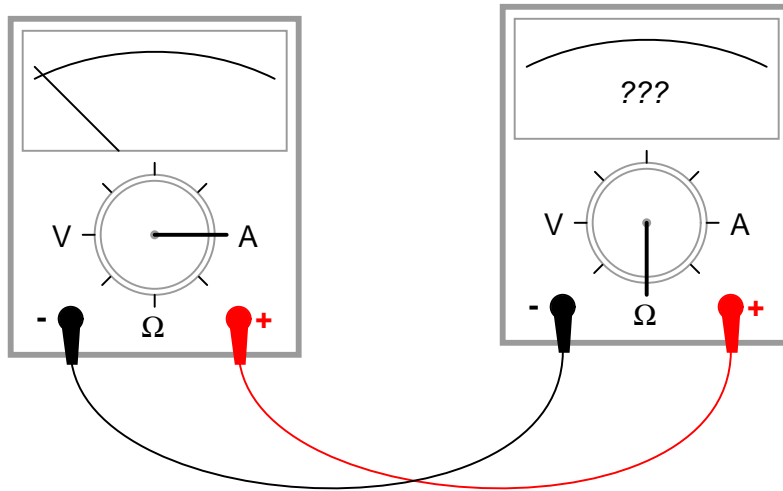

file 00272

Question 3

Why is it a very bad idea to connect an ammeter directly across a voltage source, like this?

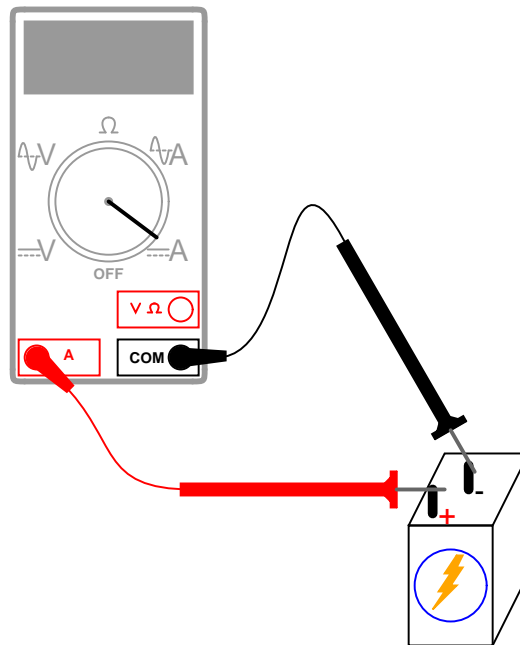

file 00070

Question 4

In this circuit, is the light bulb lit? Why or why not?

Also, compare the relative indications of the two ammeters (which ammeter registers the greatest amount of current, and which ammeter registers the least amount of current, or do they both register the same amount of current?).

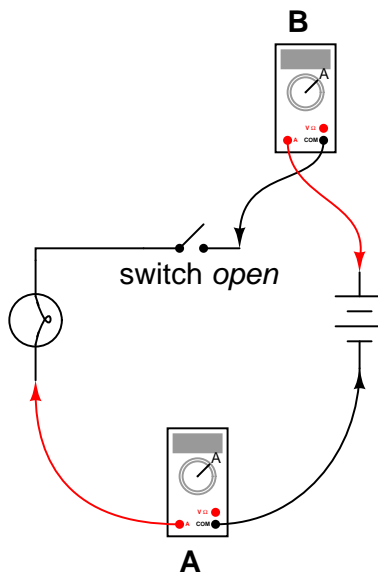

file 00023

Question 5

In this circuit, is the light bulb lit? Why or why not?

Also, compare the relative indications of the two ammeters (which ammeter registers the greatest amount of current, and which ammeter registers the least amount of current, or do they both register the same amount of current?).

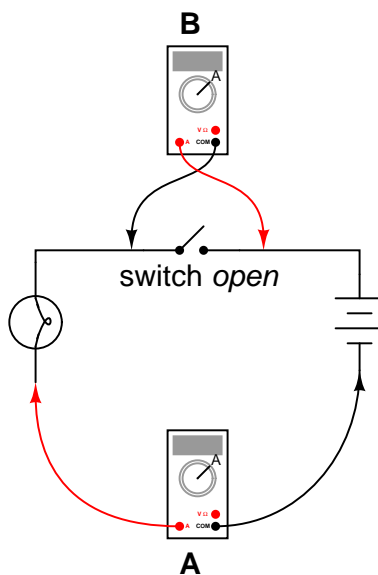

file 00025

Question 6

In this circuit, is the light bulb lit? Why or why not?

Also, compare the relative indications of the two ammeters (which ammeter registers the greatest amount of current, and which ammeter registers the least amount of current, or do they both register the same amount of current?).

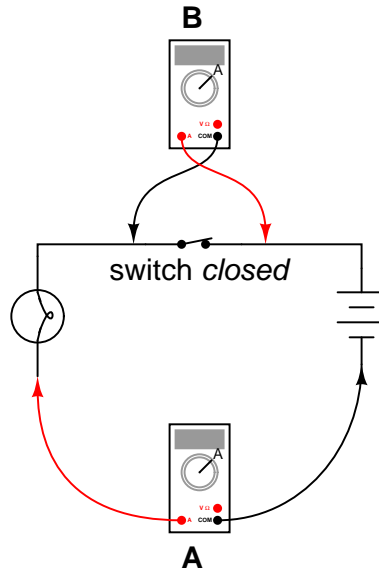

file 00029

Question 7

Generally speaking, is an ammeter supposed to be connected in *series* or in *parallel* with the component it's measuring current through?

file 00273

Question 8

Shown here is a circuit constructed on a PCB (a "Printed Circuit Board"), with copper "traces" serving as wires to connect the components together:

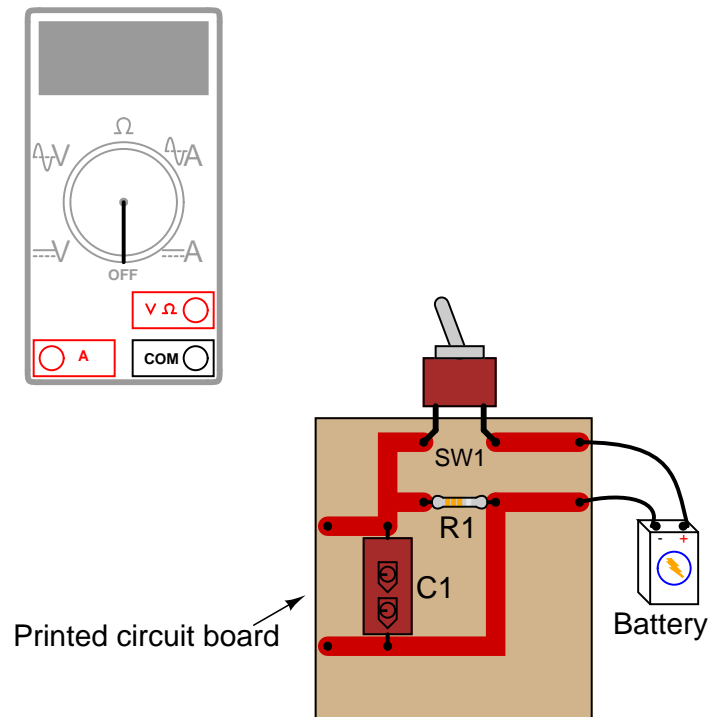

How would the multimeter be used to measure the current through the component labeled "R1" when energized? Include these important points in your answer:

- The configuration of the multimeter (selector switch position, test lead jacks)
- The connections of the meter test leads to the circuit
- The state of the switch on the PCB (open or closed)

file 00097

Question 9

What would happen if a multimeter were connected across the component labeled "C1" on this printed circuit board, as shown?

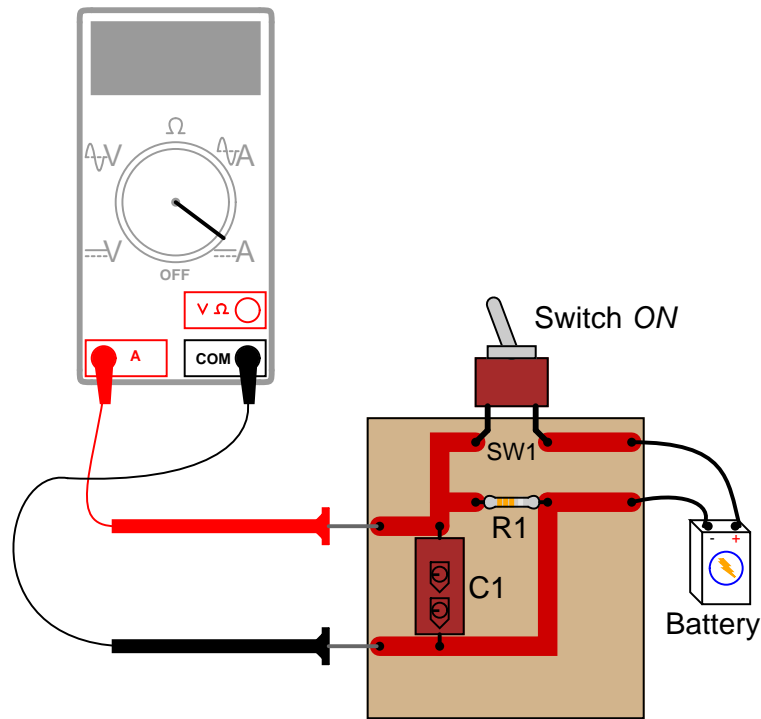

[file 00098](#)

Question 10

Most ammeters contain *fuses* inside to provide protection for the person using the ammeter, as well as for the ammeter mechanism itself. Voltmeters generally do *not* contain fuses inside, because they are unnecessary.

Explain why ammeters use fuses and voltmeters do not? What is it about the nature of an ammeter and how it is used that makes fuse-protection necessary?

[file 00274](#)

Question 11

Ammeters must be connected in *series* with the current to be measured, to ensure that all the current moves through the meter:

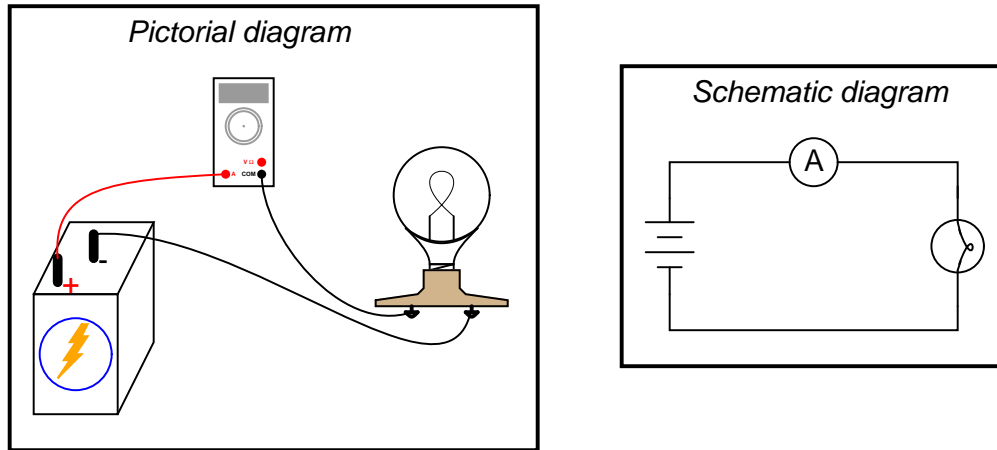

In order to practically function, an ammeter must have some internal resistance. It is usually a very small amount, but it does exist. It should be apparent to you that the presence of this resistance will have some effect on the circuit current, when compared to the amount of current in the circuit without any meter connected:

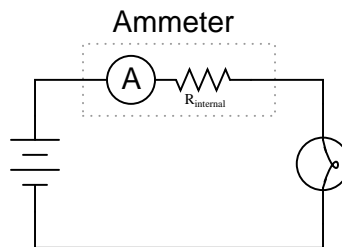

Explain why it is usually safe to ignore the internal resistance of an ammeter, though, when it is in a circuit. A common term used in electrical engineering to describe this intentional oversight is *swamping*. In this particular circuit an engineer would say, "The resistance of the light bulb *swamps* the internal resistance of the ammeter."

file 03638

Answer 1

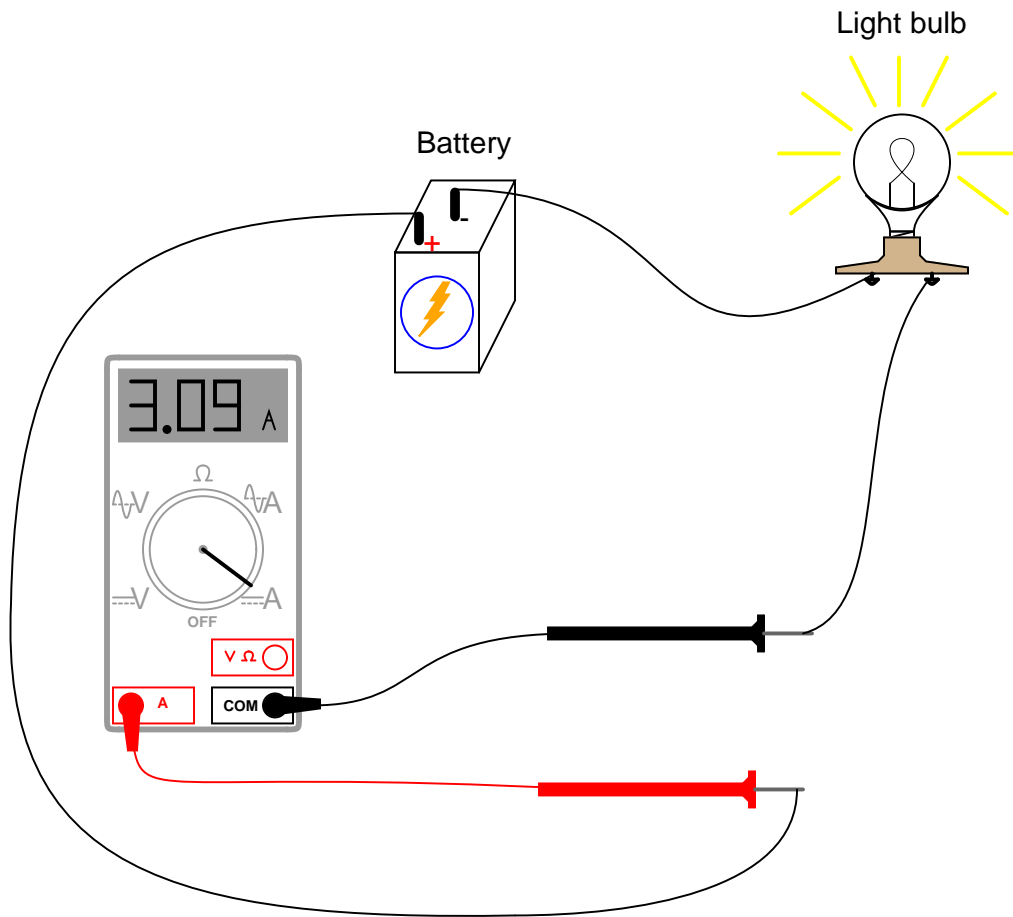

(Note: the meter's indication of 3.09 amps is arbitrary, and not important to the question).

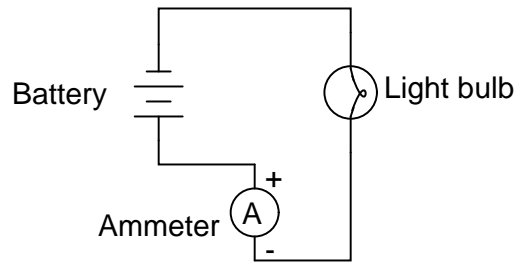

Answer 2

The ohmmeter should register a very low resistance.

Answer 3

Due to the ammeter's very low resistance, it will "draw" a lot of current from the voltage source. In effect, the ammeter will form a short circuit with the voltage source, potentially damaging the meter and/or the source.

In applications where the voltage source possesses very little internal resistance of its own, the current surge resulting from such a short-circuit may be huge. Very large surges of electric current are capable of heating wires to the point where their insulation bursts into flames, as well as causing super-heated blasts of *plasma* (electrically ionized gas) to form at any point of electrical contact where there is a spark. Either of these high-temperature conditions are hazardous to the person holding the meter and test leads!

Answer 4

The bulb is not lit, and the two ammeters both register 0 amperes of current.

Answer 5

The bulb is lit, and the two ammeters register equal amounts of current.

Answer 6

The bulb is lit, but ammeter "A" registers much more current than ammeter "B".

Answer 7

Series.

Answer 8

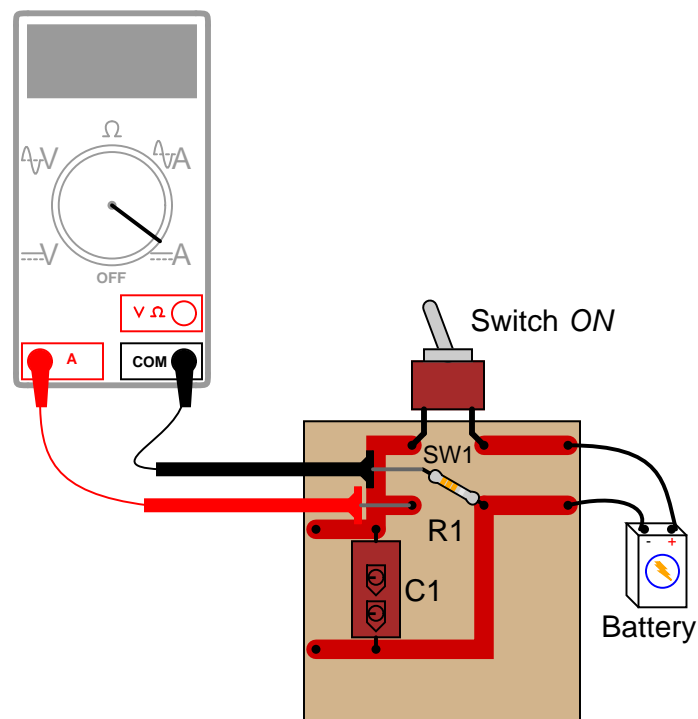

In order to measure current through resistor R1, one of its leads must be de-soldered from the circuit board so that the meter may be connected directly in-line (in *series*) with it.

Answer 9

The meter would create a short-circuit with the battery. Determine what damage this short-circuit might cause, to all components involved.

Answer 10

The purpose of the fuse inside the ammeter is to "blow" (open-circuit) in the event of excessive current through the meter.

Answer 11

When one quantity "swamps" another, we mean that its effect is huge compared to the effect of the other, so much so that we may safely ignore it in our calculations and still arrive at a reasonably accurate result.

Notes

Notes 1

The important thing for students to understand in this question is that the ammeter must become part of the path that the electric current flows through. Explain how this fact contains an element of danger, as contrasted against the relatively "non-invasive" connection of a voltmeter to a circuit.

Notes 2

Ask your students *why* an ammeter should have a very low resistance (fractions of an ohm) between its test leads. How does this property of all ammeters relate to how they are used to measured current in real circuits?

Notes 3

An important point to discuss is how electrical safety encompasses more than just shock hazard. In particular, *arc blasts* caused by high-current "faults" such as this may be just as dangerous as electric shock. At the very least, placing an ammeter directly across the terminals of a voltage source will likely result in the ammeter's fuse being blown.

In some cases, ammeter fuses are more expensive than one might think. Safety-rated ammeters often use expensive fast-action fuses with significant current interruption ratings. In the case of the Fluke 187 and 189 multimeters, these fuses cost around \$8 each (American dollars, 2004)!

Notes 4

It is vitally important for students to understand the significance of continuity throughout the entire circuit, not just at one or more points in the circuit.

Notes 5

This is a good question to engage students' thinking on meter properties. A voltmeter does not function the same as an ammeter, and the two different types of meters will impact circuits differently when connected! Incidentally, ammeters tend to get you into more trouble than voltmeters when troubleshooting circuits, which is why students should be encouraged to use a voltmeter whenever possible rather than an ammeter. Of course, clamp-on ammeters are not as unsafe as ammeters requiring direct connection with circuit conductors.

Notes 6

Exactly what ammeter "B" will register (aside from its indication being less than ammeter "A"), is an interesting question.

Notes 7

If your students don't already know, this question is an excellent opportunity for them to learn about what a "series" circuit is and how it differs from a "parallel" circuit. Ask your students *why* "series" is the correct answer. What is it about a series connection that makes it the best type of connection to use an ammeter in? What would happen if we connected an ammeter in *parallel* with a circuit component?

Notes 8

Many multimeters use "international" symbols to label DC and AC selector switch positions. It is important for students to understand what these symbols mean.

As you can see in this answer, measuring current through components is generally more difficult than measuring voltage across components, and involves greater risk because the meter must conduct the component's full current (which in some cases may be significant). For this reason, technicians need to learn troubleshooting techniques prioritizing voltage measurements over current measurements.

Notes 9

Even though it might not appear that the meter is "shorting" the battery in this example, it most certainly is. In asking students to determine the resulting damage from such an action, it is important for them to trace the path of "fault current" through the circuit. Those components within the path of fault current are in risk of damage, while those components not within the path of fault current are not at risk.

Notes 10

This is a very important question for several reasons. First, it alerts students that ammeters are generally fuse-protected, and therefore they must be aware that this fuse could "blow" and render the ammeter inoperative. Secondly, it highlights one of the major differences between voltmeters and ammeters, and that is the amount of current typically handled by the respective meter types.

Notes 11

I have found that the concept of "swamping" is extremely useful when making estimations. To be able to ignore the values of some components allows one to simplify a great many circuits, enabling easier calculations to be performed.